

Installation Manual

Montageanleitung • Notice de montage • Istruzione per il montaggio

Element shed C16-1817

Elementhaus • Maison à modules • Casetta in elementi

Art.-No. 0800.020

Measurements 185x170 cm

Grösse • Dimensions • Misure



March • März • Mars • Marzo 2006

The producer shall have the right to make technical changes to the product • Technische Änderungen vorbehalten • Le producteur réserve le droit d'effectuer des modifications techniques au produit • Il produttore mantiene il diritto di apportare modifiche tecniche al prodotto

Installation manual – English



Dear client,

We are glad that you have decided in favour of our garden house!

Please read the assembly manual carefully before proceeding with the house installation!
You will thus avoid problems and will not waste time.

Recommendations:

- Keep the house package until its complete assembly in a dry place, but not in direct contact with the ground, protected from weather conditions (moisture, the sun, etc.). Do not keep the house package in a heated room!
- Please inspect the delivery for its completeness in accordance with the list of pieces (Specification list) before assembly. Sort the components and place them at the four sides of the house in the installation sequence.



Warranty

Your house is made from high quality spruce and delivered in the natural (unprocessed) form. If, despite our thorough inspection, you should have complaints, please submit the filled out control sheet and purchase invoice to the product seller.

ATTENTION: Please be sure to keep the documentation accompanying the house package! The control sheet includes the control number of the house. We can only review complaints if you submit the control number of the house to the seller!

The warranty does not cover:

- Peculiarities of wood as a natural material
- Wooden details already painted (processed with a wood preservative)
- Wooden details containing whole branches that do not endanger the stability of the house
- Colour tone variations caused by wood structure differences that do not influence wood lifetime
- Wooden details containing (caused by drying) small cracks/gaps that do not pass through and do not influence the structure of the house
- Twisted wooden details if they can nevertheless be installed
- Roof and floor boards that may have on their concealed surfaces some non-planed areas, colour differences and waning
- Complaints resulting from an incompetent manner of the installation of the house or the house subsiding due to an incompetently made foundation

The complaints covered by the warranty are satisfied to the extent of replacing the deficient/faulty material. All other demands will be excluded!

We shall have the right to make technical changes to the product.



Garden house painting and maintenance

Wood is a natural material, growing and adapting depending on weather conditions. Large and small cracks, colour tone differences and changes, as well as a changing structure of wood are not errors, but a result of wood growing and a peculiarity of wood as a natural material.

Unprocessed wood becomes greyish after having been left untouched for a while, and can be turn blue and become mouldy. To protect the wooden details of your garden house, you must immediately process them with a wood preservative.

We recommend that you cover the boards in advance with a colourless wood impregnation agent, especially the boards, to which you will no longer have access when the house is assembled. Only this will prevent moisture penetration.

After the house assembly is completed, we recommend for the conclusive finishing a weather protection paint that will protect wood from moisture and UV radiation.

When painting, use high quality tools and paints, follow the paint application manual and manufacturer's safety and usage instructions. Never paint a surface in strong sunlight or rainy weather. Consult a specialist regarding paints suitable for unprocessed softwood and follow the paint manufacturer's instructions.

Having been properly painted, your garden house's lifetime will increase substantially. We recommend that you inspect the house thoroughly once every six months.



We wish you total success with the garden house installation and much joy with this house for many years to come!

Montageanleitung – Deutsch



Sehr geehrter Kunde,

es freut uns, dass Sie sich für unser Gartenhaus entschieden haben!

Es ist wichtig, diese Aufbauanleitung vollständig durchzulesen, bevor Sie mit dem Aufbau Ihres Blockhauses beginnen! So vermeiden Sie Probleme und unnötigen Zeitverlust.

Tipps:

- Lagern Sie den Bausatz bis zur endgültigen Montage trocken und nicht direkt auf dem Erdboden, geschützt vor Witterungseinflüssen (Nässe, Sonneneinwirkung, etc.). Ware bitte nicht in einem geheizten Raum aufbewahren!
- Bevor Sie mit dem Aufbau beginnen, kontrollieren Sie bitte die Vollständigkeit der Hausteile anhand der Stückliste. Sortieren Sie das Material und legen Sie dieses entsprechend der Aufbaureihenfolge bereit.



Gewährleistung

Ihr Haus besteht aus hochwertigem nordischen Fichtenholz und wird unbehandelt geliefert. Wenn es trotz unserer sorgfältigen Werkskontrolle zu Reklamationen kommen sollte, legen Sie Ihrem Fachhändler den ausgefüllten Kontrollschein mit Ihrer Einkaufsrechnung vor!

WICHTIG: Bitte unbedingt die Dokumentation aufbewahren! Auf dem Kontrollschein finden Sie die Kontrollnummer des Hauses. Es ist möglich die Reklamation nur dann als Garantiefall zu behandeln, wenn Sie die Kontrollnummer Ihrem Fachhändler weitergeben!

Abweichungen die keinen Reklamationsgrund darstellen:

- Holz ist ein Naturprodukt, daher gehören die naturgegebenen Beanstandungen nicht unter Garantie.
- Materialreklamationen werden nicht akzeptiert, wenn bereits ein Anstrich erfolgte!
- Äste die mit dem Holz fest verwachsen sind.
- Holzverfärbungen, ohne das dadurch die Lebensdauer beeinflusst wird.
- Risse /Trockenrisse die nicht durchgehend sind und nicht die Konstruktion beeinflussen.
- Verdrehungen des Holzes vorausgesetzt es lässt sich noch verarbeiten.
- An den nicht sichtbaren Seiten von Dach- und Fussbodenbrettern können die Bretter ungehobelt sein, es können Farbunterschiede und Baumkanten vorkommen.
- Spätere Reklamation durch unsachgemässe Montage, Absacken des Hauses durch unsachgemässe Fundamente und Gründungen sind ausgeschlossen.

Ansprüche auf Gewährleistung beschränken sich auf den Austausch von fehlerhaftem Material. Alle weiteren Ansprüche sind ausgeschlossen!

Bitte berücksichtigen Sie, dass wir uns technische Änderungen vorbehalten.



Anstrich und Pflege

Holz ist ein Naturprodukt und arbeitet unterschiedlich. Merkmale wie grobe und feine Maserungen, Farbschattierungen und Veränderungen sowie Verwachsungen haben Ihren Ursprung im Wuchs des Baumes. Sie sind bei Hölzern, die in der freien Natur wachsen, normal und deshalb nicht als Fehler, sondern vielmehr als Eigentümlichkeit des Naturwerkstoffes Holz anzusehen.

Das unbehandelte Holz wird nach einiger Zeit vergrauen, kann verbläuen und verschimmeln. Um ihr Haus zu schützen, sollten Sie es mit geeigneten Holzschutzmitteln behandeln.

Sie sollten Ihr Gartenhaus vor dem Zusammenbau streichen. So erreichen Sie, dass auch an später nicht mehr zugänglichen Stellen ein schützender Anstrich vorhanden ist. Wir empfehlen zunächst einen Voranstrich mit Imprägniergrund und danach einen Anstrich mit einer Holzschutzlasur.

Beim Anstrich benutzen Sie hochwertiges Werkzeug und Farbe, beachten Sie die Sicherheits- und Verarbeitungshinweise des Farbenherstellers. Streichen Sie nie in praller Sonne oder beim regnerischen Wetter. Lassen Sie sich ausführlich bei Ihrem Fachhändler über den Holzschutz für unbehandelte Nadelhölzer beraten.

Durch einen regelmässigen Anstrich beeinflussen Sie im Wesentlichen die Lebensdauer Ihres Gartenhauses. Wir empfehlen Ihnen auch eine halbjährliche Inspektion des Gartenhauses.



Wir wünschen Ihnen nun viel Spass und Erfolg beim Aufbau und jahrelange Freude mit Ihrem Gartenhaus!

Notice de montage – Français



Cher client,

Nous sommes heureux que votre choix se soit porté sur notre maison de jardin!

Il est important de lire entièrement cette notice de montage avant de commencer la construction de votre maisonnette en poutres! Vous vous éviterez ainsi des problèmes et des pertes de temps inutiles.

Conseils:

- Avant son montage définitif, entreposez le kit de construction au sec et pas directement sur la terre, en le protégeant contre les intempéries (humidité, rayonnement du soleil, etc.). Ne pas conserver la marchandise dans un local chauffé!
- Avant l'installation, vérifiez selon les caractéristiques (Liste des pièces détails) si tous les détails vous sont délivrés. Triez le matériel et placez-le selon l'ordre des travaux d'installation.



Garantie

Votre maisonnette est réalisée en bois d'épicéa nordique de haute qualité et elle vous est livrée non traitée. Si elle devait donner lieu à des réclamations, malgré les soins apportés à notre contrôle en usine, nous vous demandons de remettre à votre revendeur spécialisé le bon de contrôle rempli et votre facture d'achat!

IMPORTANT: Veuillez impérativement conserver la documentation! Vous trouverez sur le bon de contrôle le numéro de contrôle de la maisonnette. La réclamation ne peut être traitée dans le cadre de la garantie que si vous communiquez le numéro de contrôle à votre revendeur spécialisé!

Ecarts qui ne constituent pas un motif de réclamation:

- Le bois est un produit naturel, ce qui fait que les réclamations reposant sur des phénomènes naturels ne tombent pas sous le coup de la garantie.
- Les réclamations concernant les matériaux ne sont pas acceptées si une peinture a déjà été appliquée!
- Nœuds qui sont inhérents au bois.
- Décolorations du bois qui n'exercent pas d'influences sur la durée de vie.
- Fissures / fentes de retrait qui ne sont pas traversantes et qui n'exercent pas d'influences sur la construction.
- Déformations du bois, sous réserve qu'il puisse encore être mis en œuvre.
- Sur les faces non visibles des planches du toit et du plancher, il se peut que les planches ne soient pas rabotées, on peut observer des différences de couleur et des flaches.
- Une réclamation tardive résultant d'un montage incorrectement réalisé, d'un affaissement de la maisonnette par suite de fondations et de soubassements incorrectement réalisés, est exclue.

Les recours en garantie se limitent au remplacement du matériel défectueux. Tous les autres recours sont exclus!

Rappelez-vous que nous nous réservons le droit d'opérer à des changements techniques.



Peinture et entretien

Le bois est un produit naturel qui travaille de façon variable. Des caractéristiques telles que les madures grossières et fines, les nuances de couleurs et les modifications, de même que les imbrications, ont leur origine dans la croissance du bois. Dans le cas de bois qui poussent en pleine nature, ces caractéristiques sont normales et ne doivent par conséquent pas être considérées comme des défauts mais, au contraire, comme une particularité de ce matériau naturel qu'est le bois.

Au bout de quelque temps, le bois non traité prendra une teinte grise, il pourra bleuir et moisir. Pour protéger votre maisonnette, il convient que vous le traitiez avec des produits de protection du bois appropriés.

Peignez votre maisonnette avant le montage. Ainsi, il sera possible de protéger avec la peinture également les surfaces inaccessibles plus tard. Nous recommandons de faire le traitement préliminaire de la surface avec une couche d'imprégnation et ensuite, avec des peintures fongicides.

Pour la peinture, n'utilisez qu'un outillage et une peinture de haute qualité, et respectez les consignes de sécurité et de mise en œuvre du fabricant de peintures. Ne peignez jamais en plein soleil ou lorsque le temps est à la pluie. Faites-vous conseiller de façon détaillée par votre revendeur spécialisé quant à la protection à utiliser pour les conifères non traités.

En refaisant régulièrement la peinture, vous augmentez sensiblement la durée de vie de votre maison de jardin. Nous vous conseillons également une inspection semestrielle de votre maison de jardin.



Nous vous souhaitons beaucoup de moments heureux, une installation réussie et beaucoup d'années joyeuses dans votre maisonnette!

Istruzioni di montaggio – Italiano



Gentile Cliente,

siamo veramente lieti che Lei abbia scelto la nostra casetta di legno per il Suo giardino!

E' importante leggere accuratamente le istruzioni prima di iniziare con il montaggio della Sua casetta di legno! In tal modo eviterà qualsiasi problema e perdita di tempo.

Consigli:

- Conservare il kit in luogo asciutto e non direttamente sul pavimento, protetto da agenti atmosferici (acqua, sole ecc.) fino al montaggio definitivo. Non conservare il prodotto in ambienti riscaldati !
- Prima di iniziare il montaggio della casa, controllate la completezza degli elementi in base all'apposita lista (Lista degli elementi). Dividere il materiale e predisporre i componenti della casetta nella sequenza indicata.



Garanzia

La vostra casetta è stata realizzata con pregiato legno di abete rosso nordico e viene consegnata in stato non trattato. Qualora, nonostante il nostro accurato controllo in fabbrica, dovessero sorgere reclami, sarà necessario presentare al negoziante il certificato di controllo compilato insieme alla fattura d'acquisto!

IMPORTANTE: E' assolutamente necessario conservare la documentazione! Sul certificato di controllo è riportato il numero di controllo della casa. Reclami possono essere evasi in garanzia unicamente se comunicherete il numero di controllo al vostro negoziante!

Divergenze che escludono motivo di reclamo:

- Il legno è un prodotto naturale e pertanto le contestazioni relative allo stato naturale non rientrano nella garanzia.
- Reclami relativi al materiale non vengono accettati una volta verniciato!
- Rami cresciuti nel legno.
- Scolorimenti del legno che non influiscono sulla durata.
- Crepe /fessure non passanti che non compromettono la costruzione.
- Nodi nel legno a condizioni che possa ancora essere lavorato.
- Nei punti invisibili del tavolame tetto e pavimento sono ammesse tavole non piallate; sono inoltre ammesse differenze di colore e spigoli dell'albero.
- Reclami successivi dovuti a montaggio non conforme, cedimento della casetta a causa di fondamenta errate sono esclusi.

Le rivendicazioni di garanzia sono limitate alla sostituzione del materiale difettoso. Ogni altra rivendicazione è esclusa!

Vi preghiamo di tenere in considerazione che ci riserviamo il diritto di apportare modifiche tecniche al presente prodotto.



Verniciatura e cura

Il legno è un prodotto naturale e si muove in modo diverso. Caratteristiche quali venature grosse e fini, sfumature di colore e cambiamenti nonché nodi sono dovuti alla crescita dell'albero. Sono del tutto normali nei legni che crescono all'aperto, e pertanto non sono da considerare difetti ma piuttosto una caratteristica del legno naturale.

Il legno non trattato diventa grigio col tempo, può scolorirsi e fare la muffa. Per proteggere la vostra casetta di legno, è consigliabile trattarla con opportuni preservanti per legno.

Verniciate la vostra casa prima del montaggio. In tal modo sarà possibile proteggere con la vernice anche quelle parti che in seguito non saranno più accessibili. Consigliamo di applicare una prima mano impegnante e di coprire successivamente con una speciale vernice protettiva per legno.

Per la verniciatura, usare attrezzi e vernici di qualità e rispettare le istruzioni di sicurezza e applicazione del produttore della vernice. Non verniciare in pieno sole o in caso di pioggia. Farsi consigliare dettagliatamente dal venditore sulla protezione di legni di conifera non trattati.

Con una regolare verniciatura aumenterete notevolmente la durata della vostra casetta da giardino. Consigliamo un'ispezione semestrale della casetta.



Vi auguriamo successo nel montaggio della casa e speriamo che la godrete per molti anni!

Specification • Stückliste • Liste des pièces détails • Lista degli elementi

Pos. Nr.	Description Beschreibung Description Descrizione	Measurements Masse Dimensions Misure	Amount Menge Quantités Quantità
1	Side wall panel Seitenwandelement Module du mur latéral Elemento parete laterale	1870*800*48 mm	3
2	Side wall panel with window Seitenwandelement mit Fenster Module du mur latéral avec fenêtre Elemento parete laterale con la finestra	1870*800*48 mm	1
3	Rear wall panel Rückwandelement Module du mur derrière Elemento parete posteriore	1870*900*48 mm	2
4	Front wall panel Vorderwandelement Module du mur devant Elemento parete anteriore	1870*510*48 mm	1+1
5	Door panel Türelement Module de la porte Elemento della porta	1865*800*48 mm	1
6	Floor boards Fussbodenbretter Planches pour le plancher Tavole pavimento	Ver. 1: 1664*89*16 mm Ver. 2: 1664*114*16 mm	21(+1) 16(+1)
7	Foundation joists Lagerhölzer Poutre du fondement Trave delle fondamenta	1800*40*32 mm	4
8	2 side purlins and 1 ridge purlin (2 boards) 2 Seitenpfetten und 1 Firstpfette (besteht aus 2 Brettern) 2 chevrons latéraux et 1 chevron de la faîte (se compose des 2 planches) 2 arcarecci laterali e 1 arcareccio di colmo (composto di 2 assi)	1870*80*19 mm	4
9	Roof boards Dachbretter Planches du toit Assi del tetto	Ver. 1: 1090*89*16 mm Ver. 2: 1090*114*16 mm	42 34
10	Facia board Giebelblende Écran frontal Schermo frontone	1110*95*16 mm	4
11	Roofing felt batten Dachpappeleiste Plinthe pour la couverture du toit Listello cartone catramato	1110*45*16 mm	4
12	Diamond Raute (Stirnbrettabdeckung) Losange (couvre la plinthe de la croupe) Rombo (copertura del listello del pignone)		2

13	Eave edging; Door batten Traufenleiste; Türleiste Plinthe de la gouttière; Plinthe de la porte Listello della gronda; listello della porta	1870*45*16 mm	3
14	Wall batten for side wall Wandleiste für Seitenwand Plinthe du mur latéral Listello parete laterale	1790*95*16 mm	6
15	Wall batten for front wall Wandleiste für Vorderwand Plinthe du mur d'avant Listello parete anteriore	1900*95*16 mm	4
16	Wall batten for rear wall Wandleiste für Rückwand Plinthe du mur d'arrière Listello parete posteriore	1890*95*16 mm	1
17	Apex Giebel Croupe Timpano	1800*366*48 mm	2
18	Roofing felt Dachpappe Couverture du toit Cartone catramato	1*1,9 m	3
19	Window bars Fenstersprossen Barreaux pour les fenêtres Sbarre delle finestre	13*13*520 mm	1
		13*13*460 mm	1

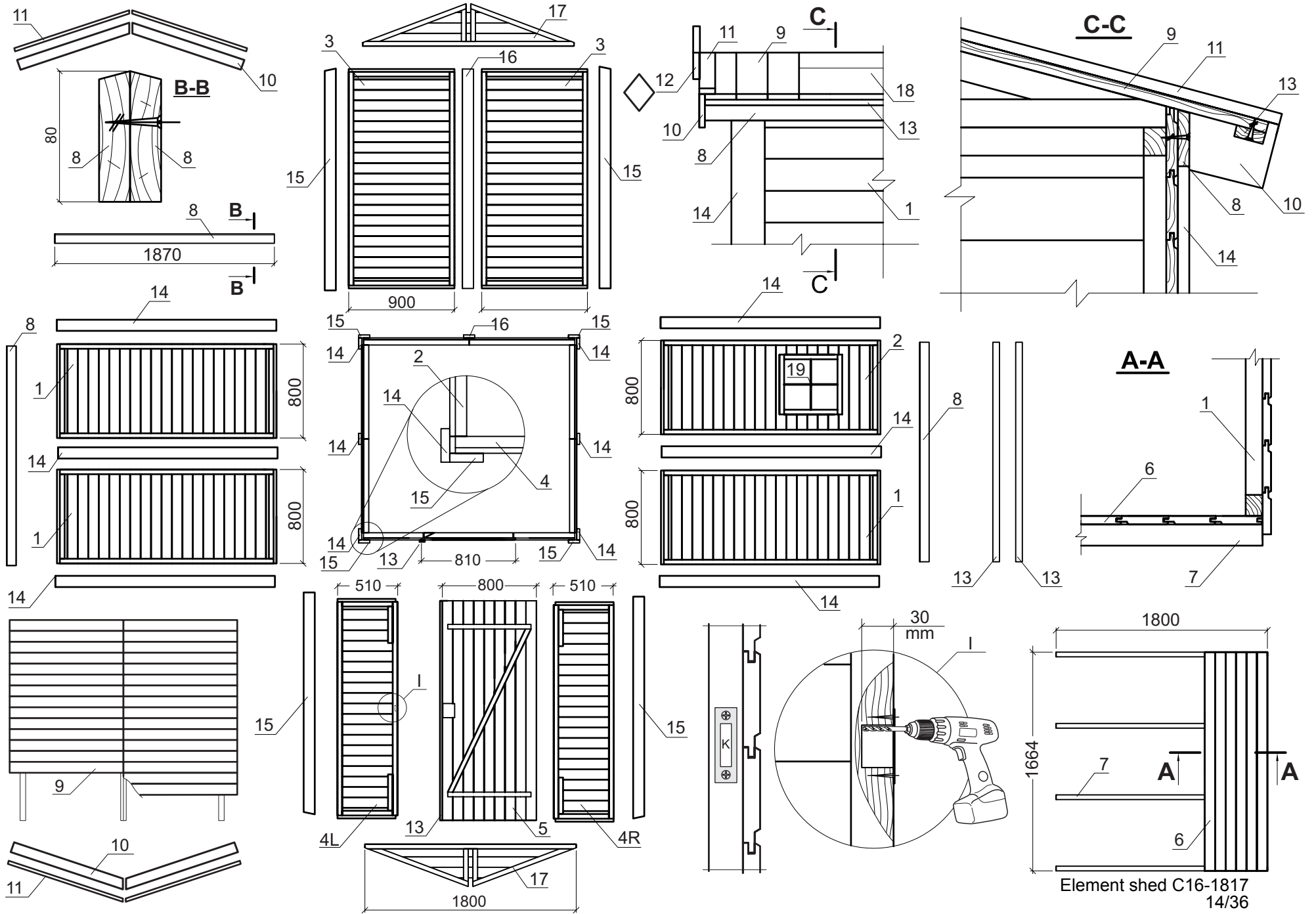

Fixing material • Befestigungsmaterial • Moyens de fixation • Strumenti di fissaggio

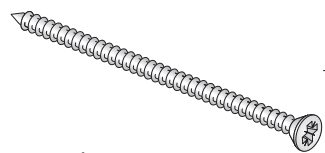

A
Ø4,5x70
x 51 st.

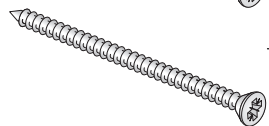

B
Ø4,5x60
x 20 st.



C
Ø3,5x40
x 106 st.



D
Ø3x35
x 12 st.



E
Ø3x30
x 20 st.



F
Ø3x16
x 3 st.



N
Ø3x20
x 4 st.



G
Ø2x16
x 80 st.



H
Ø2,5x50
x 172 st.

K
x 1 st.

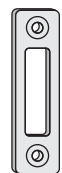

L
x 1 st.

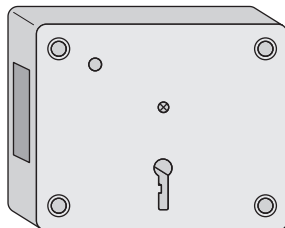

M
x 1 st.



J
x 2 st.

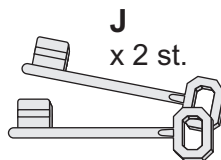

R
x 2 st.

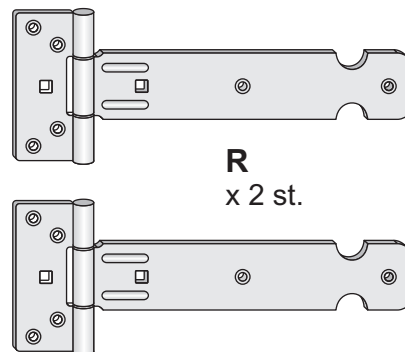

I
M6X60
x 4 st.

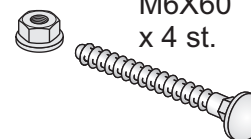

Tools • Werkzeuge • Outils • Attrezzi

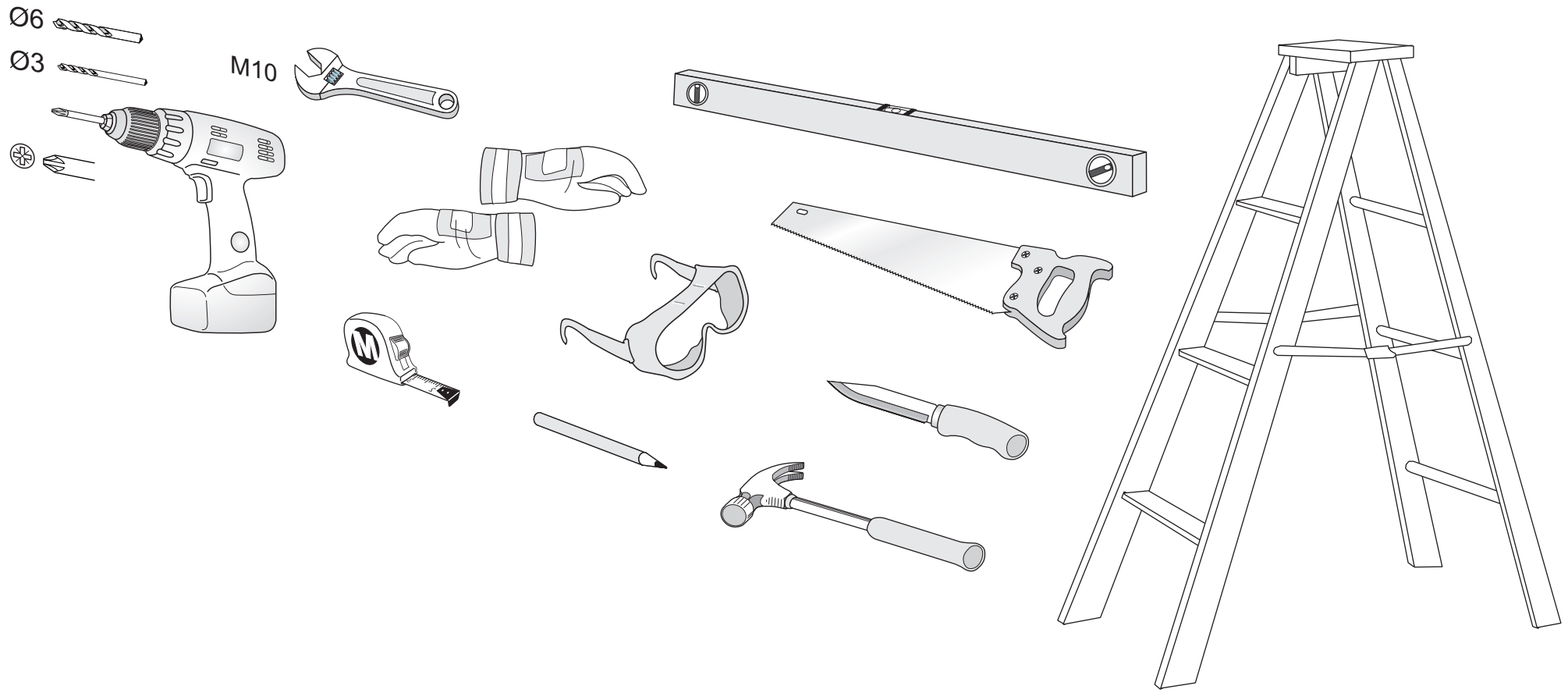
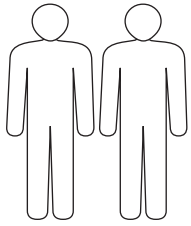

1. step: Foundation • Fundament • Fondations • Fondamento

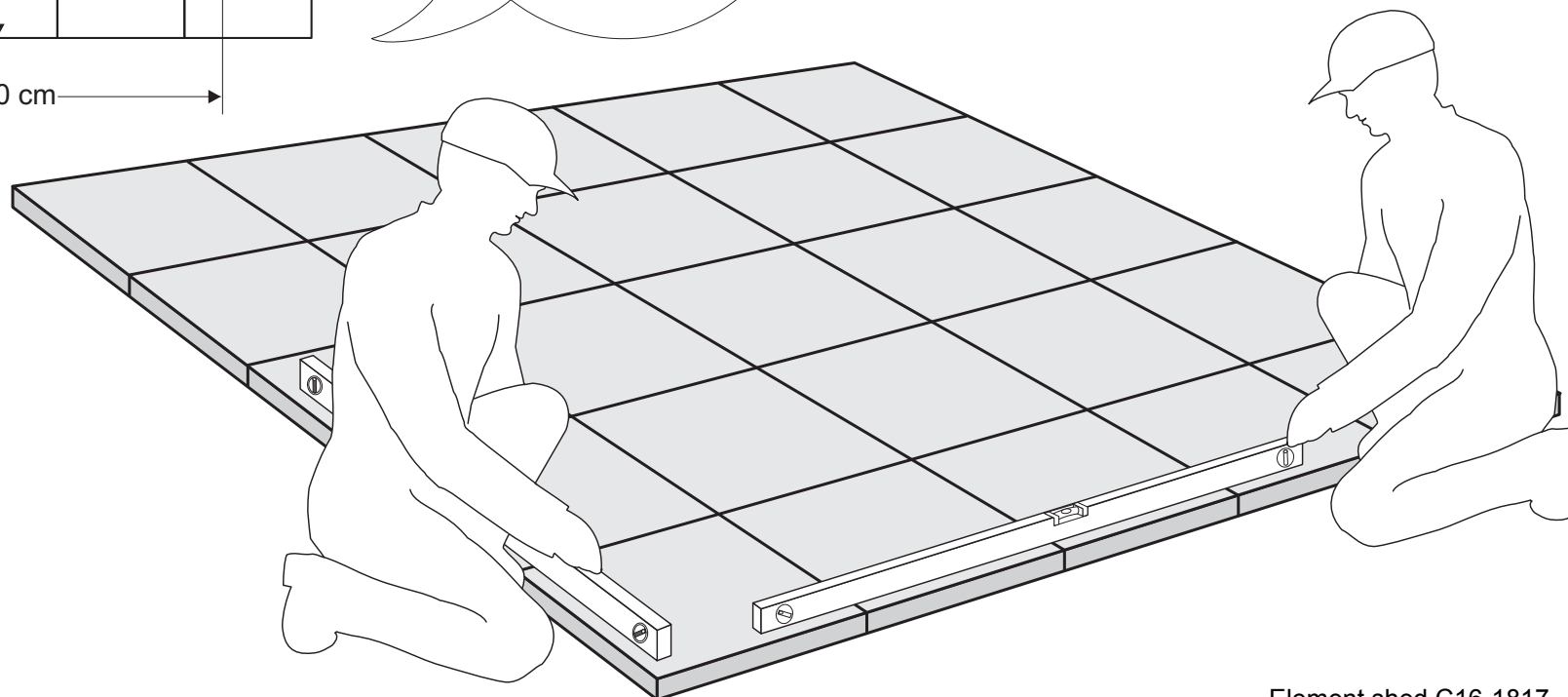
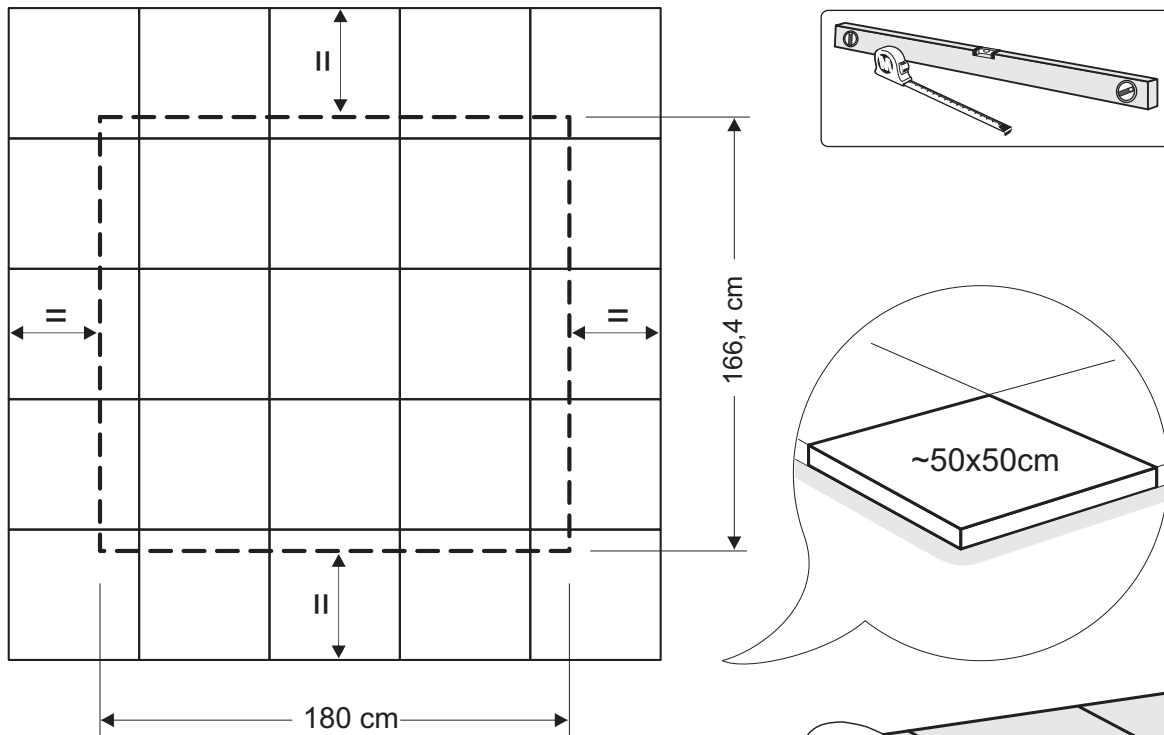

2. step: Joists layout • Fundamentplan • Plan des foundations • Progetto delle foudazioni

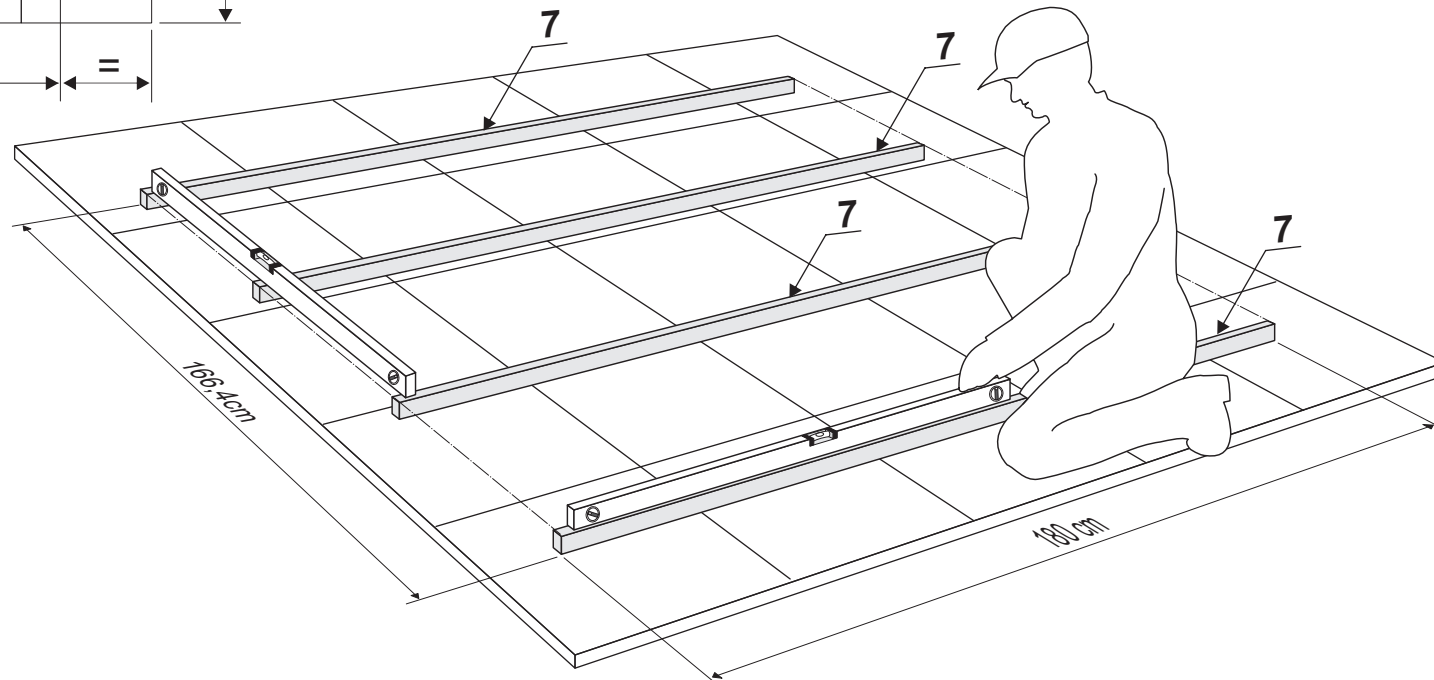
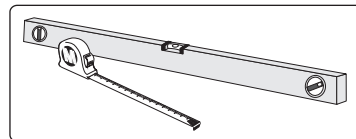
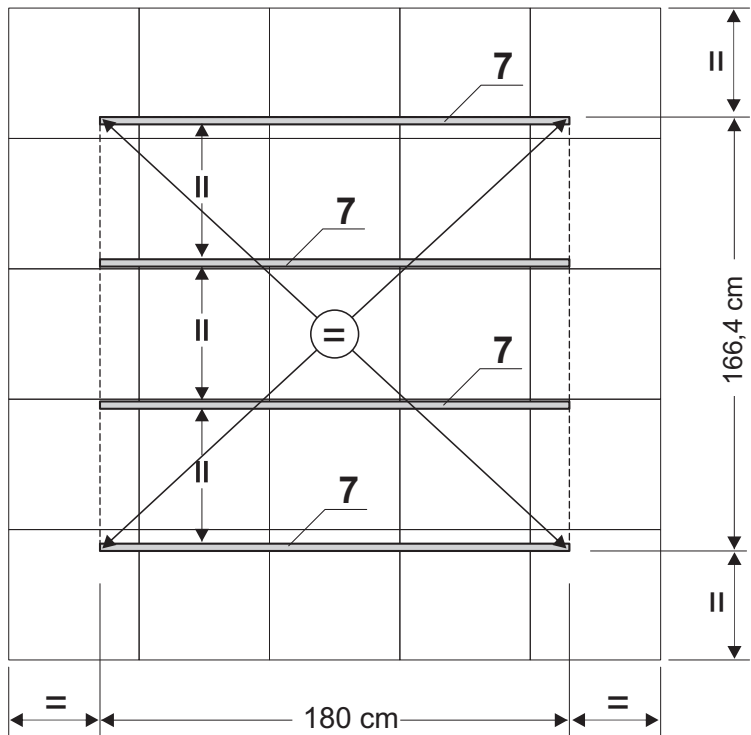

3. step: Floor boards • Fussbodenbretter • Planches pour le plancher • Tavole pavimento

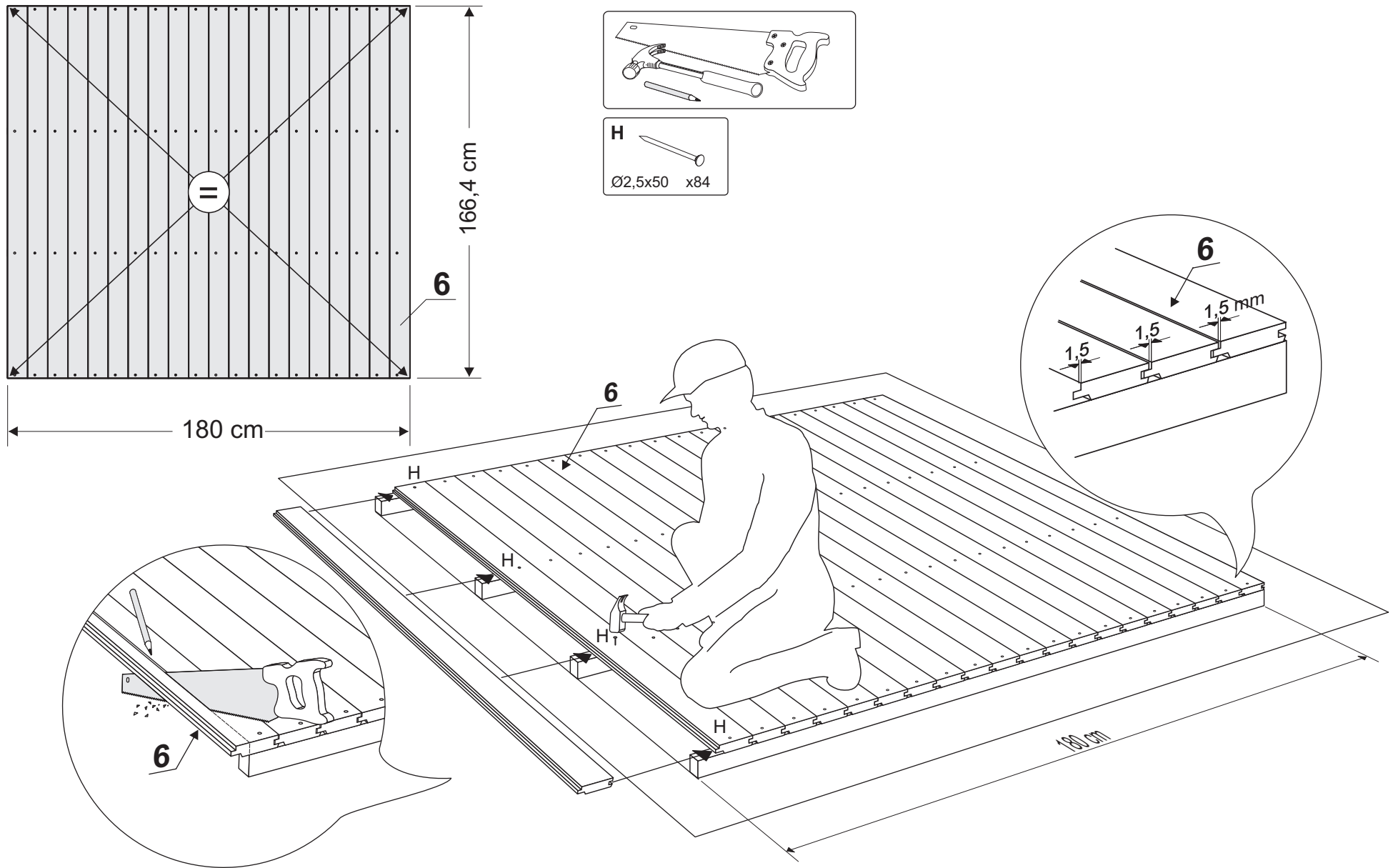

4. step: Wall elements • Wandelemente • Modules du mur • Elementi parete

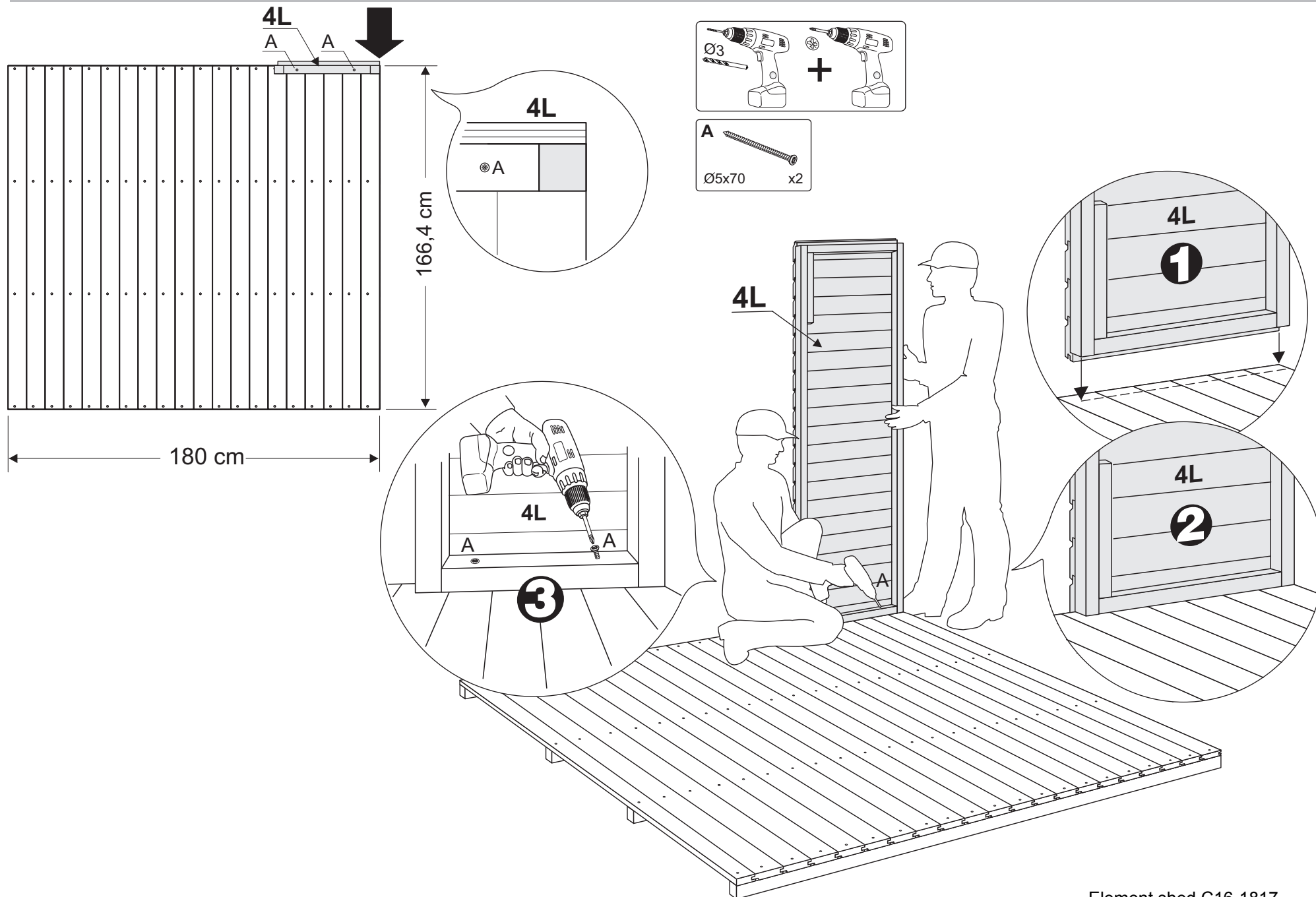

5. step: Wall elements • Wandelemente • Modules du mur • Elementi parete

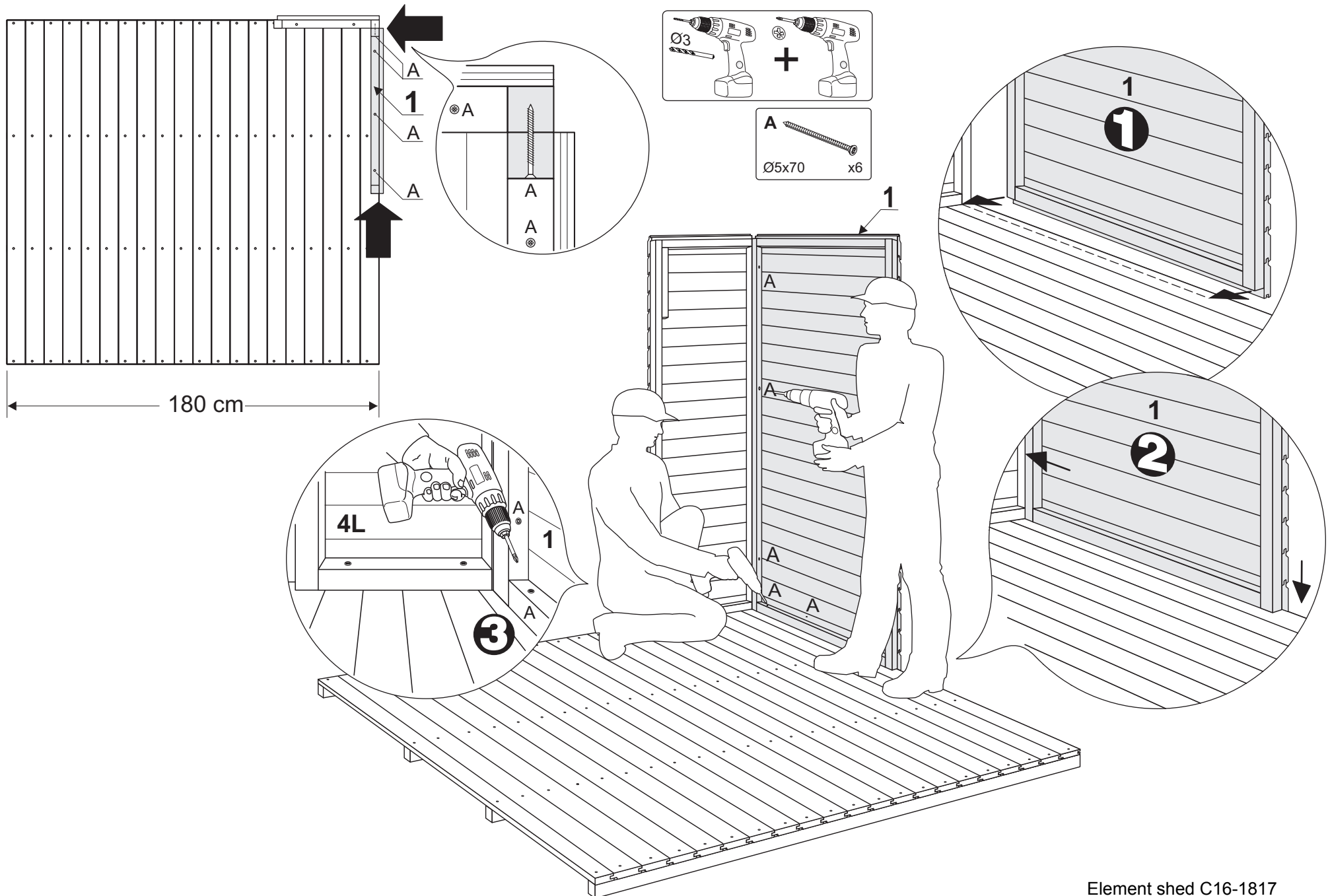

6. step: Wall elements • Wandelemente • Modules du mur • Elementi parete

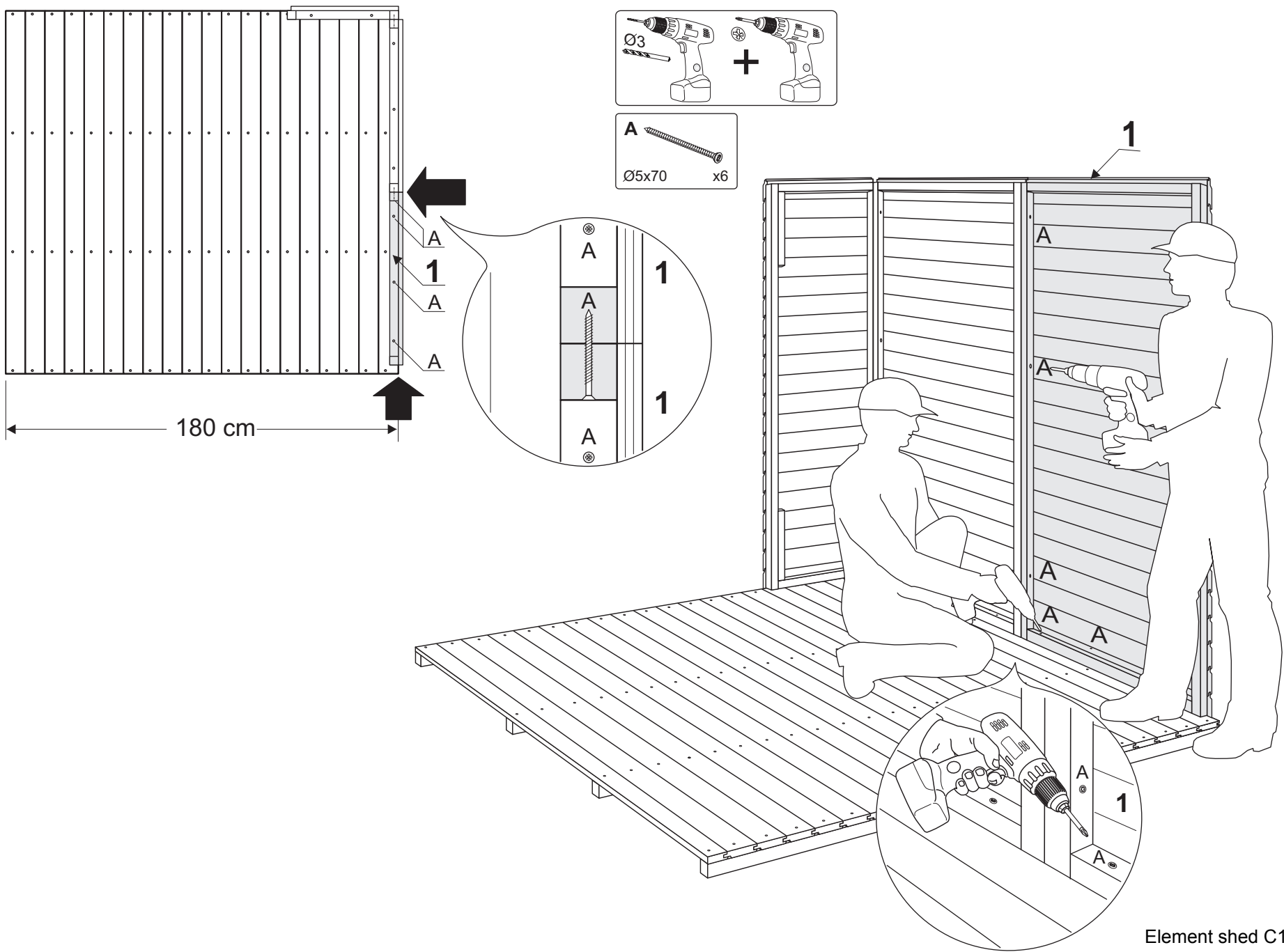

7. step: Wall elements • Wandelemente • Modules du mur • Elementi parete

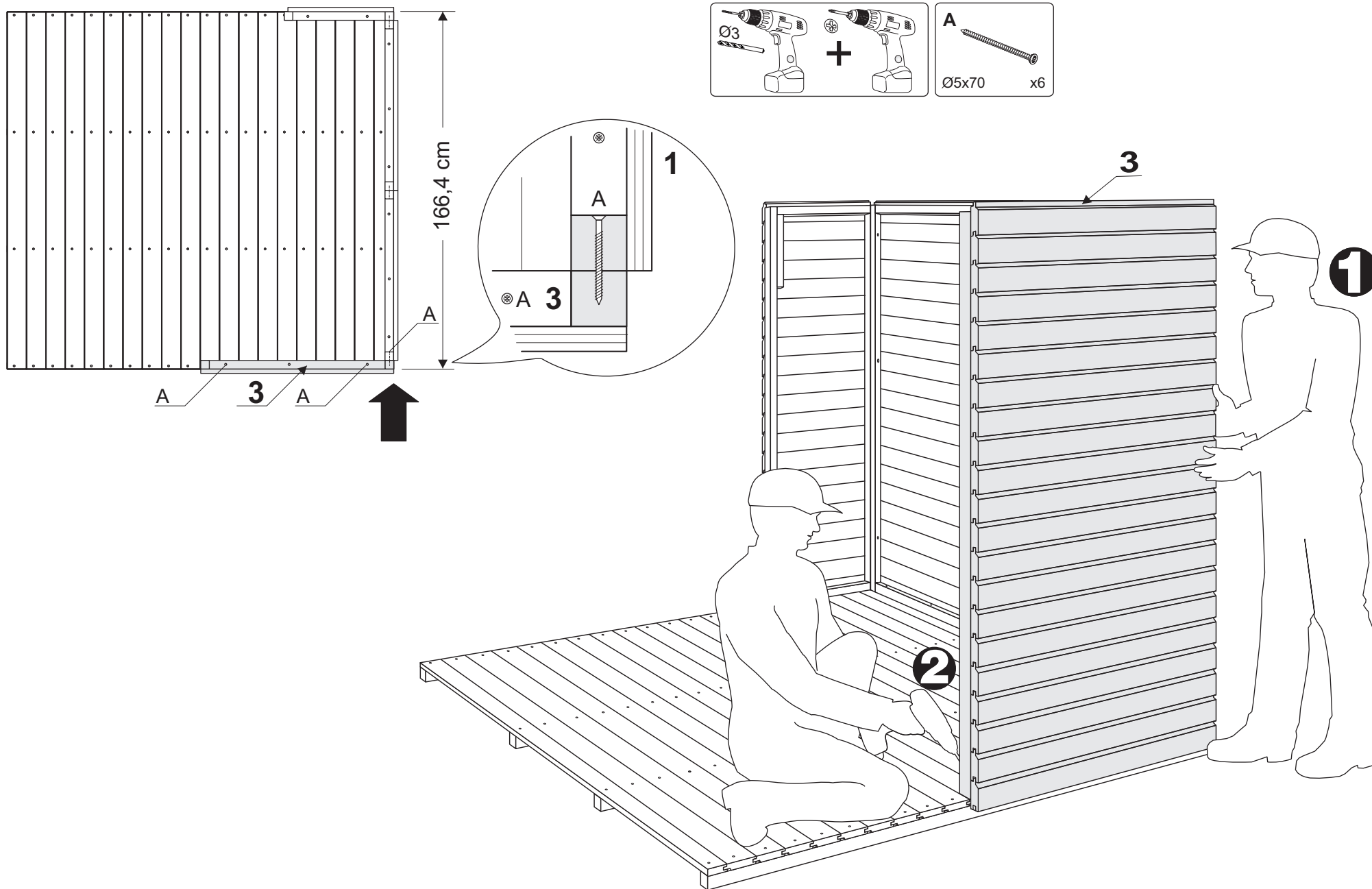

8. step: Wall elements • Wandelemente • Modules du mur • Elementi parete

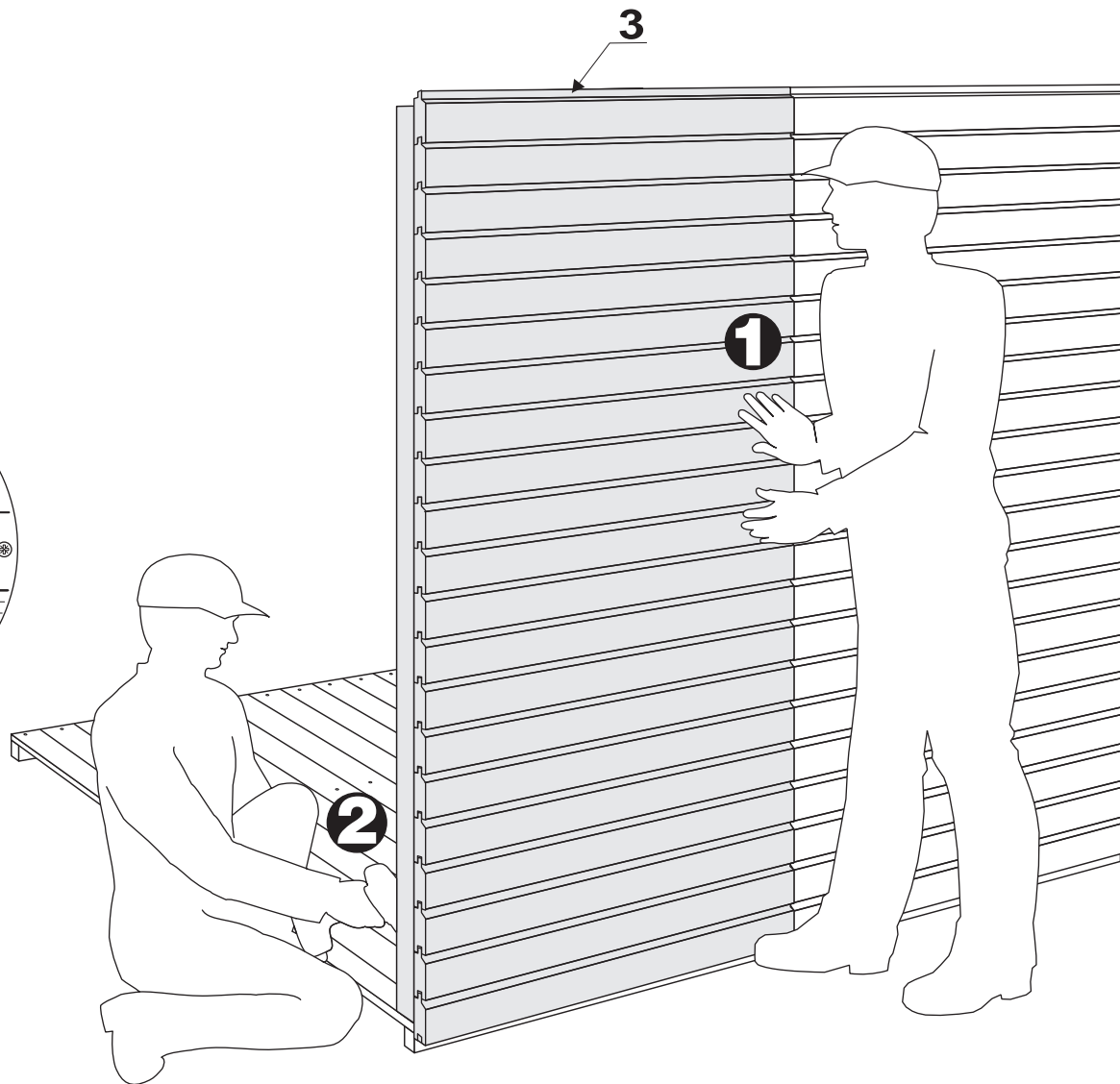
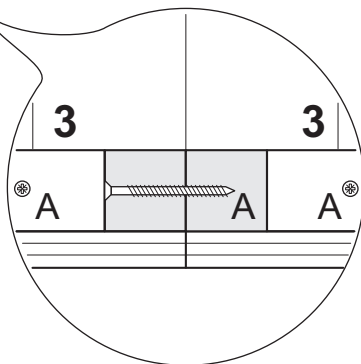
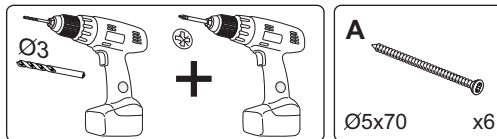
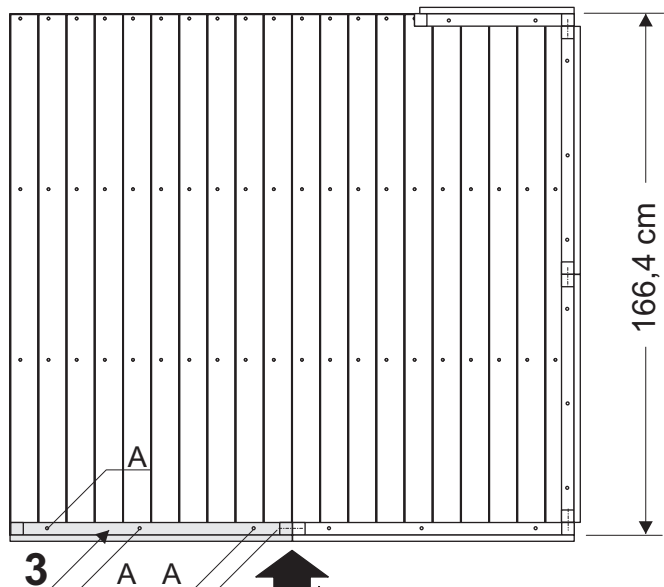

9. step: Wall elements • Wandelemente • Modules du mur • Elementi parete

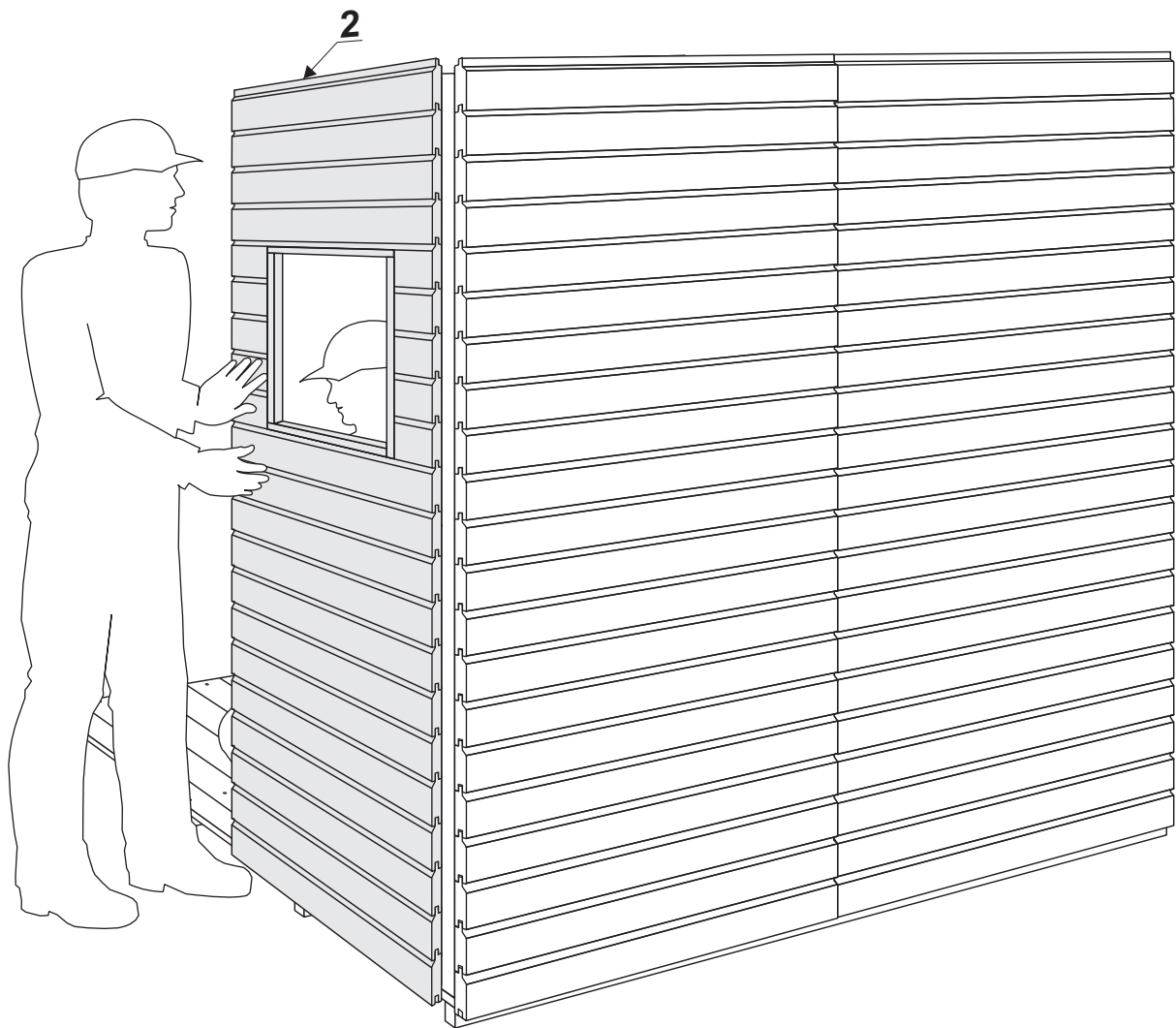
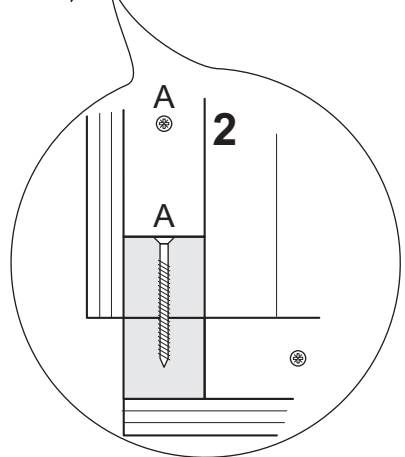
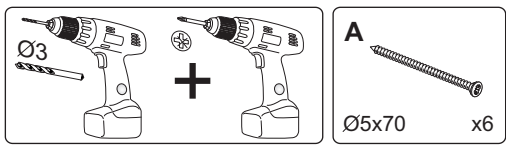
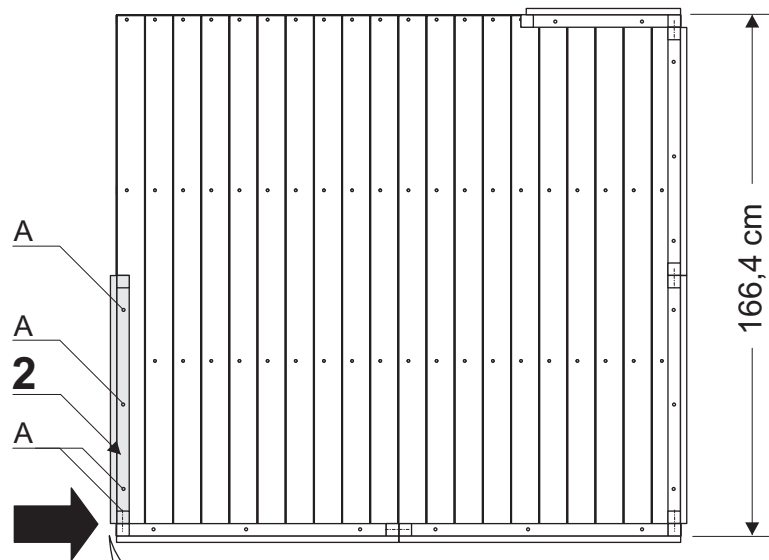

10. step: Wall elements • Wandelemente • Modules du mur • Elementi parete

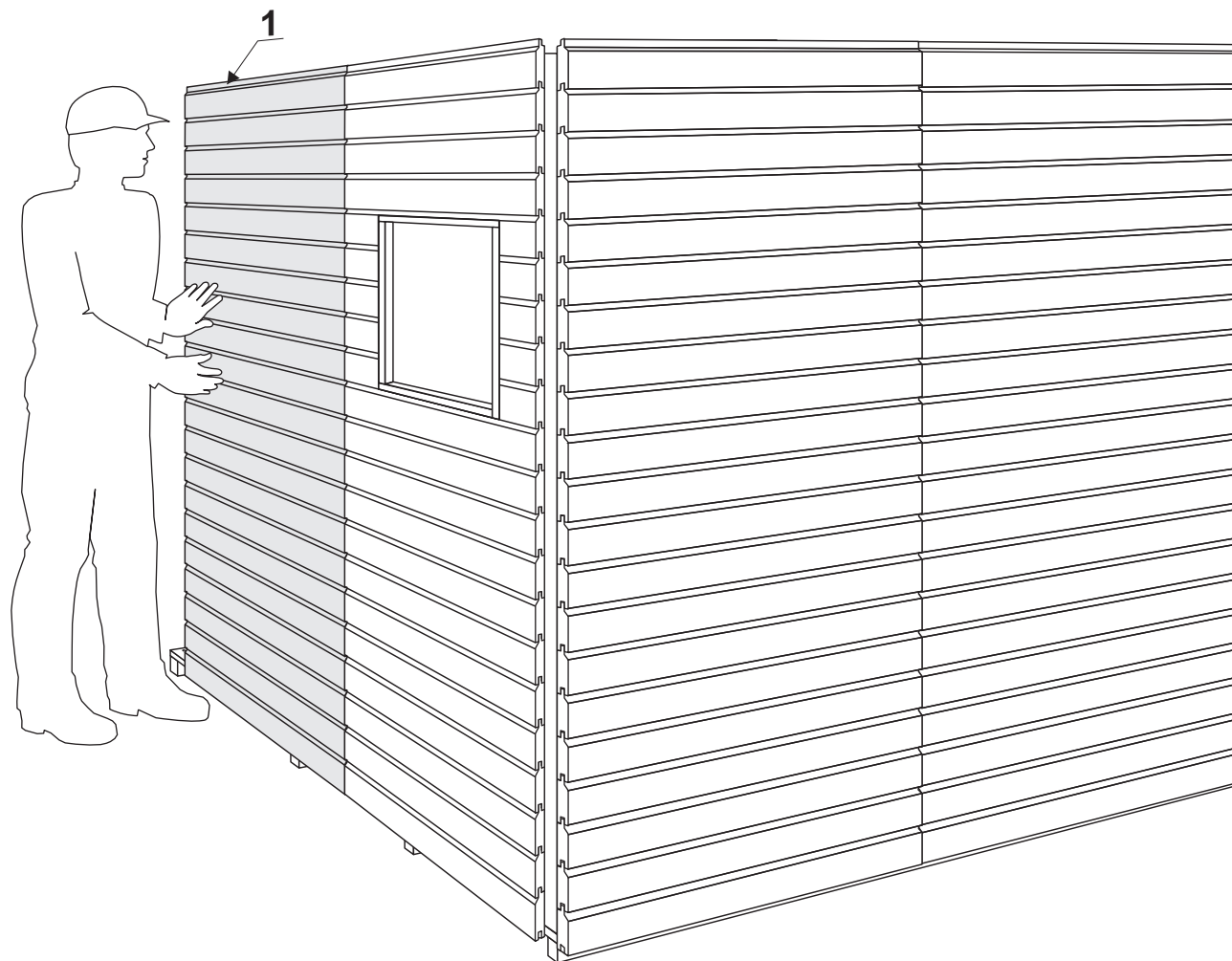
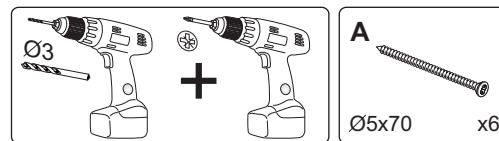
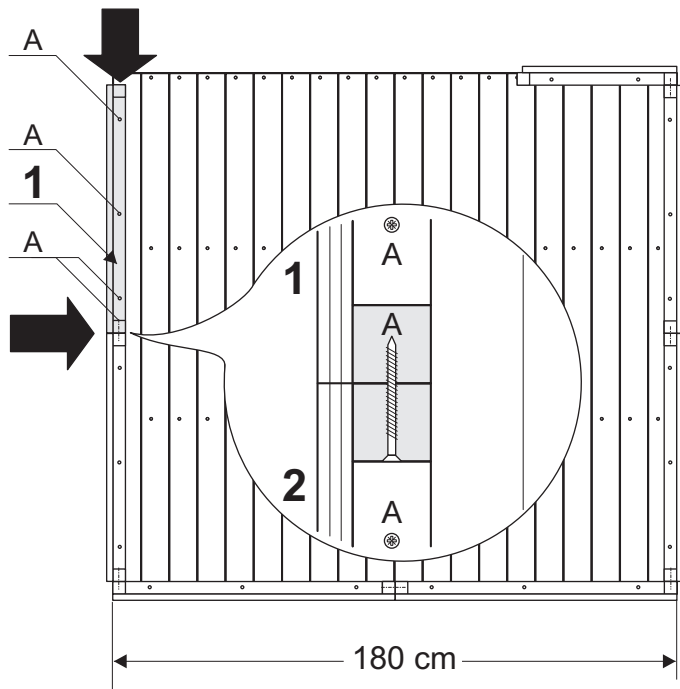

11. step: Wall elements • Wandelemente • Modules du mur • Elementi parete

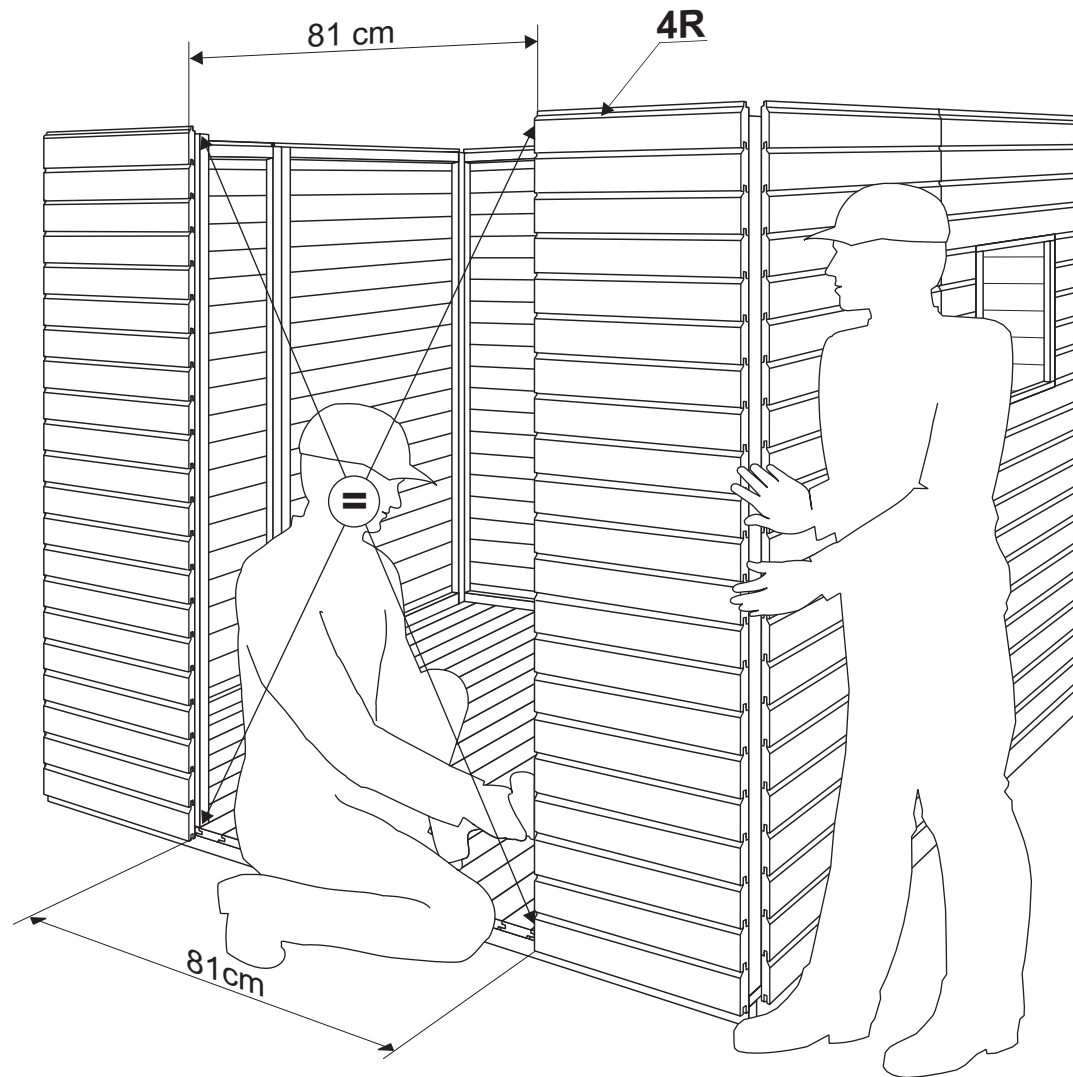
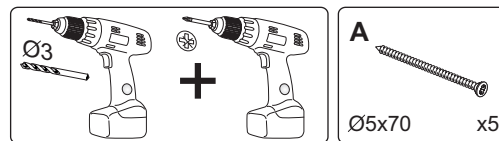
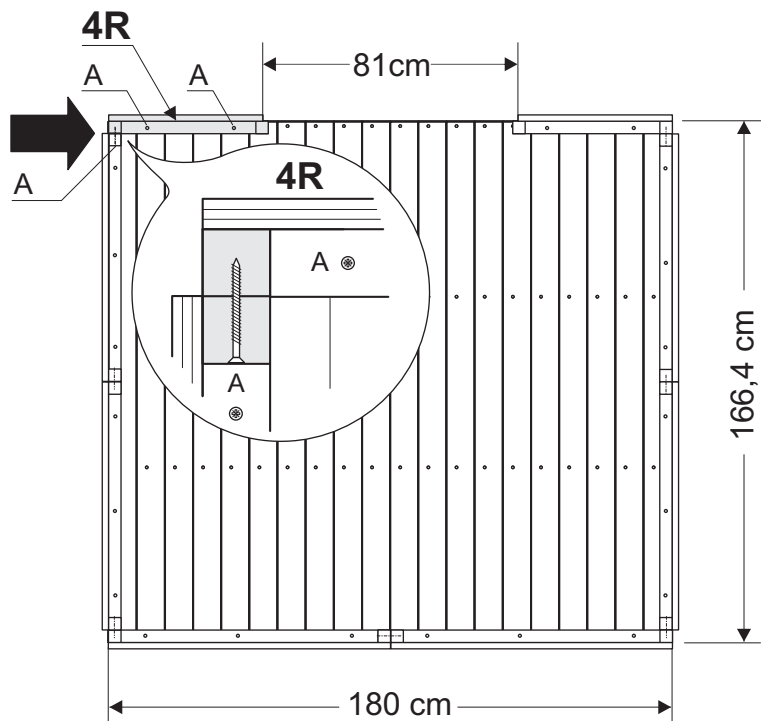

12. step: Apex • Giebel • Croupe • Timpano

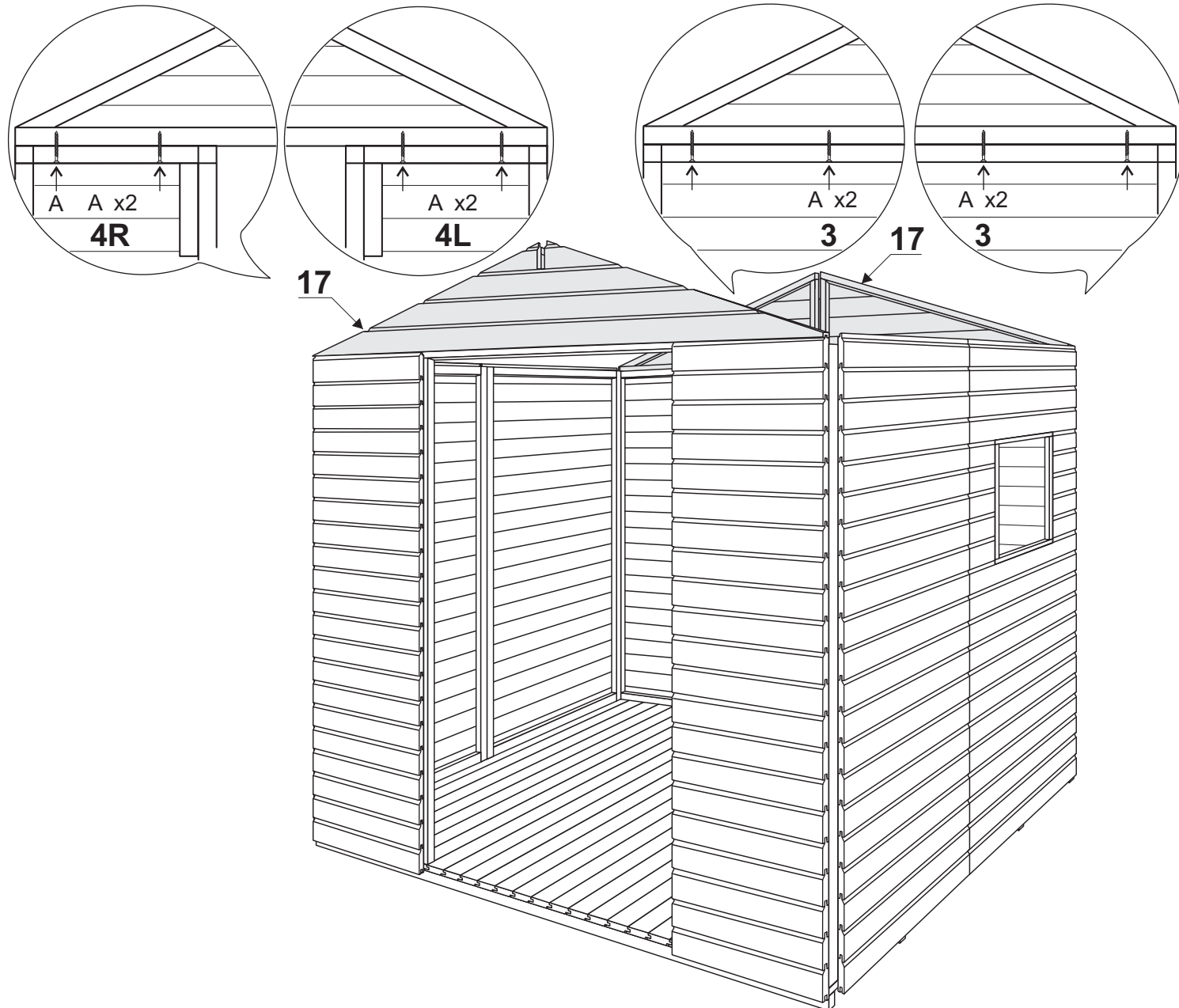
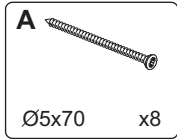
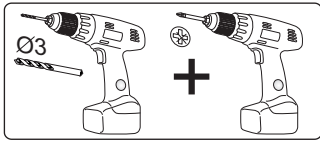

13. step: Ridge purlin • Firstpfette • Chevron de la faîte • Arcareccio di colmo

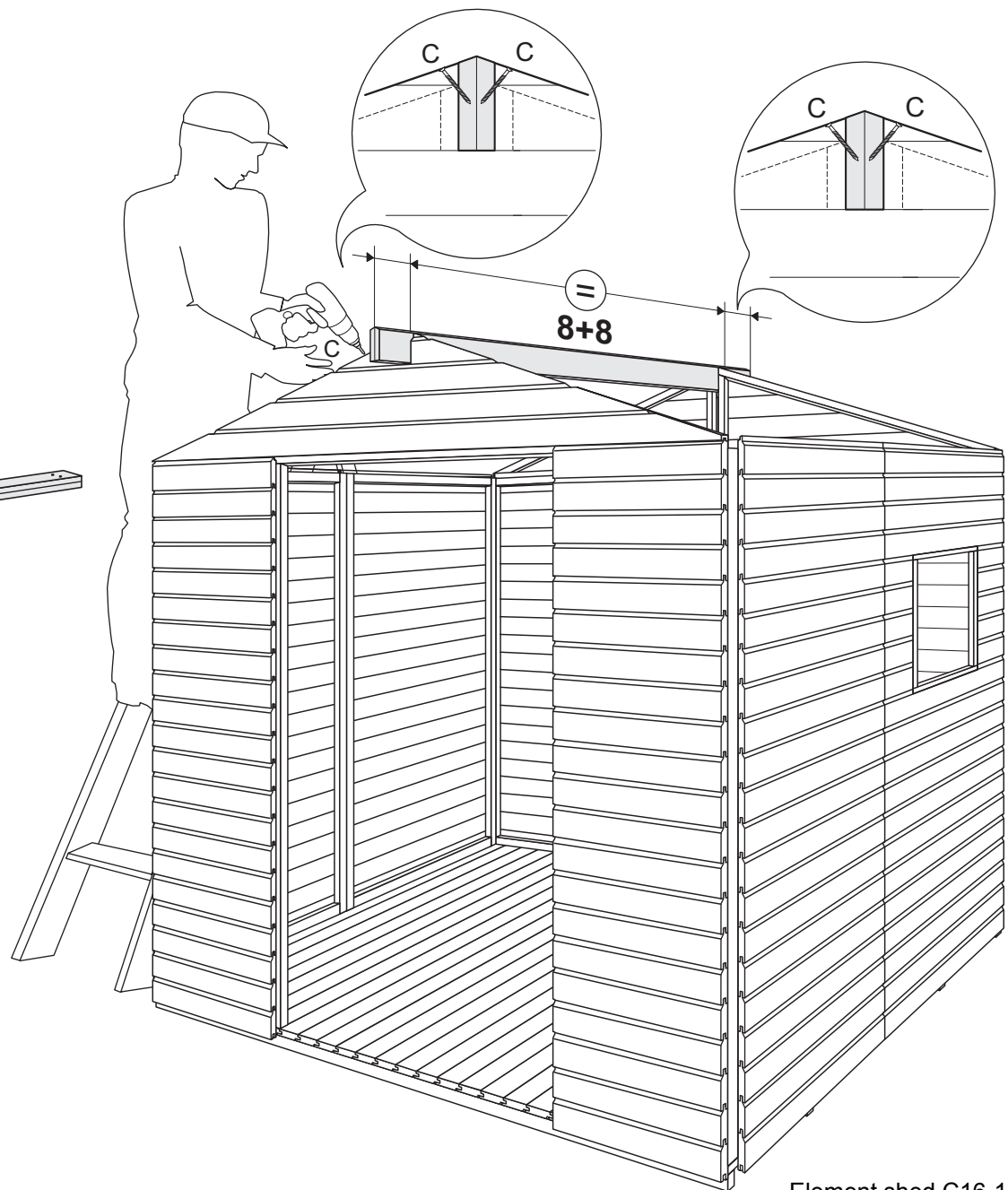
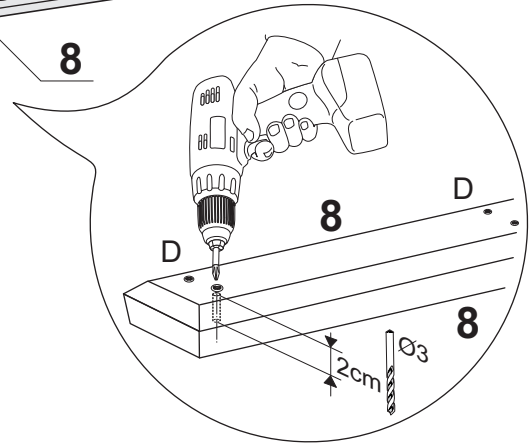
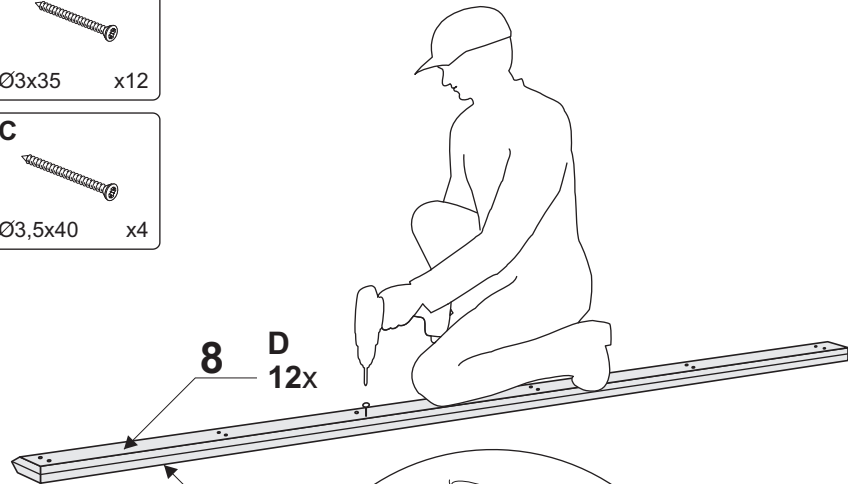
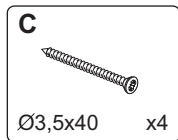
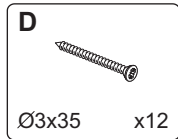
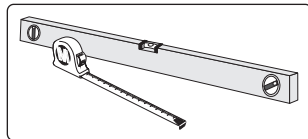
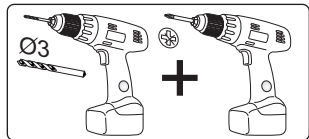

14. step: Side purlins • Seitenpfetten • Chevrons latéraux • Arcarecci laterali

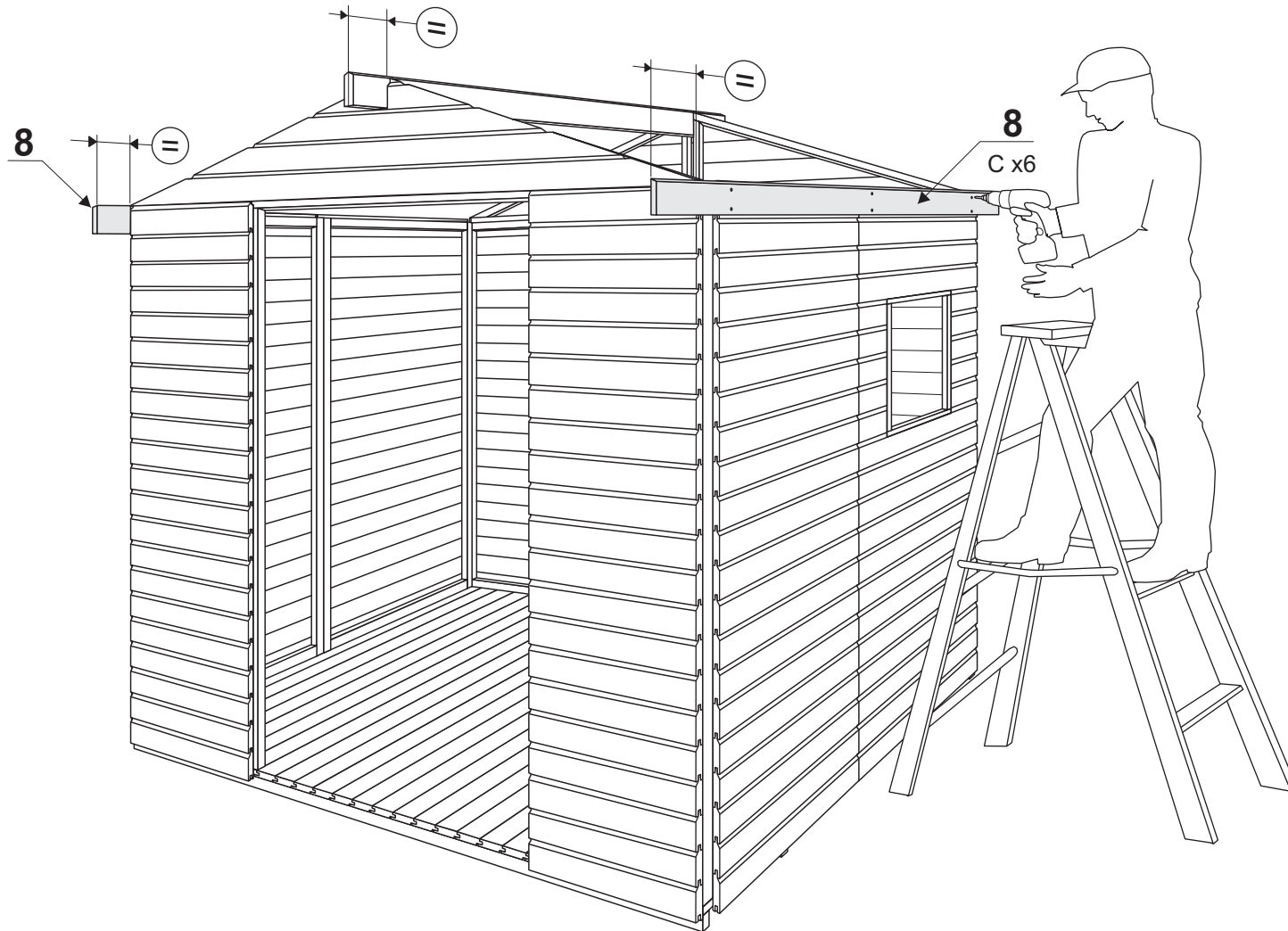
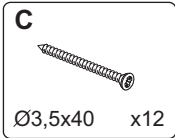
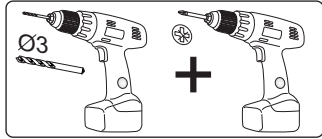
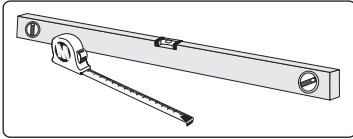

15. step: Roof boards • Dachbretter • Planches du toit • Assi del tetto

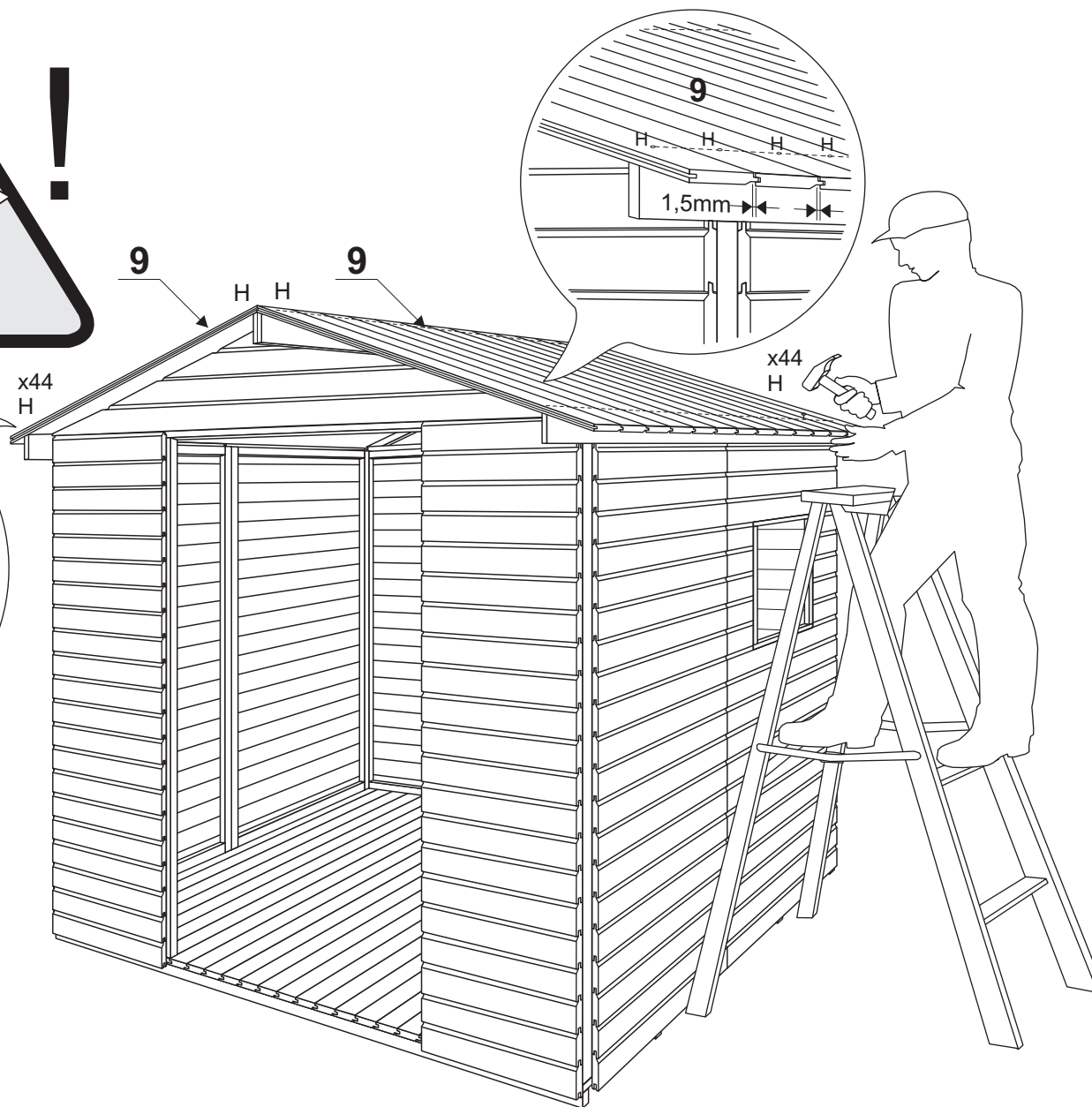
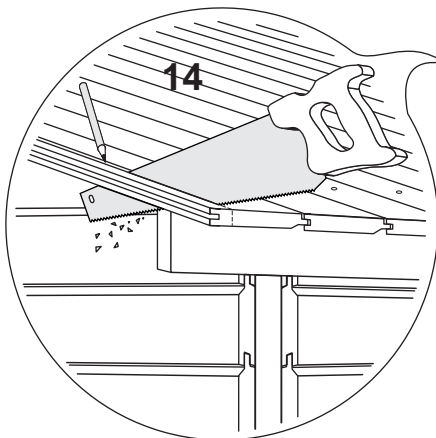
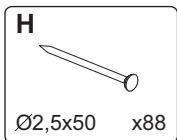
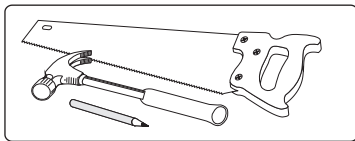

16. step: Roofing felt • Dachpappe • Couverture du toit • Cartone catramato

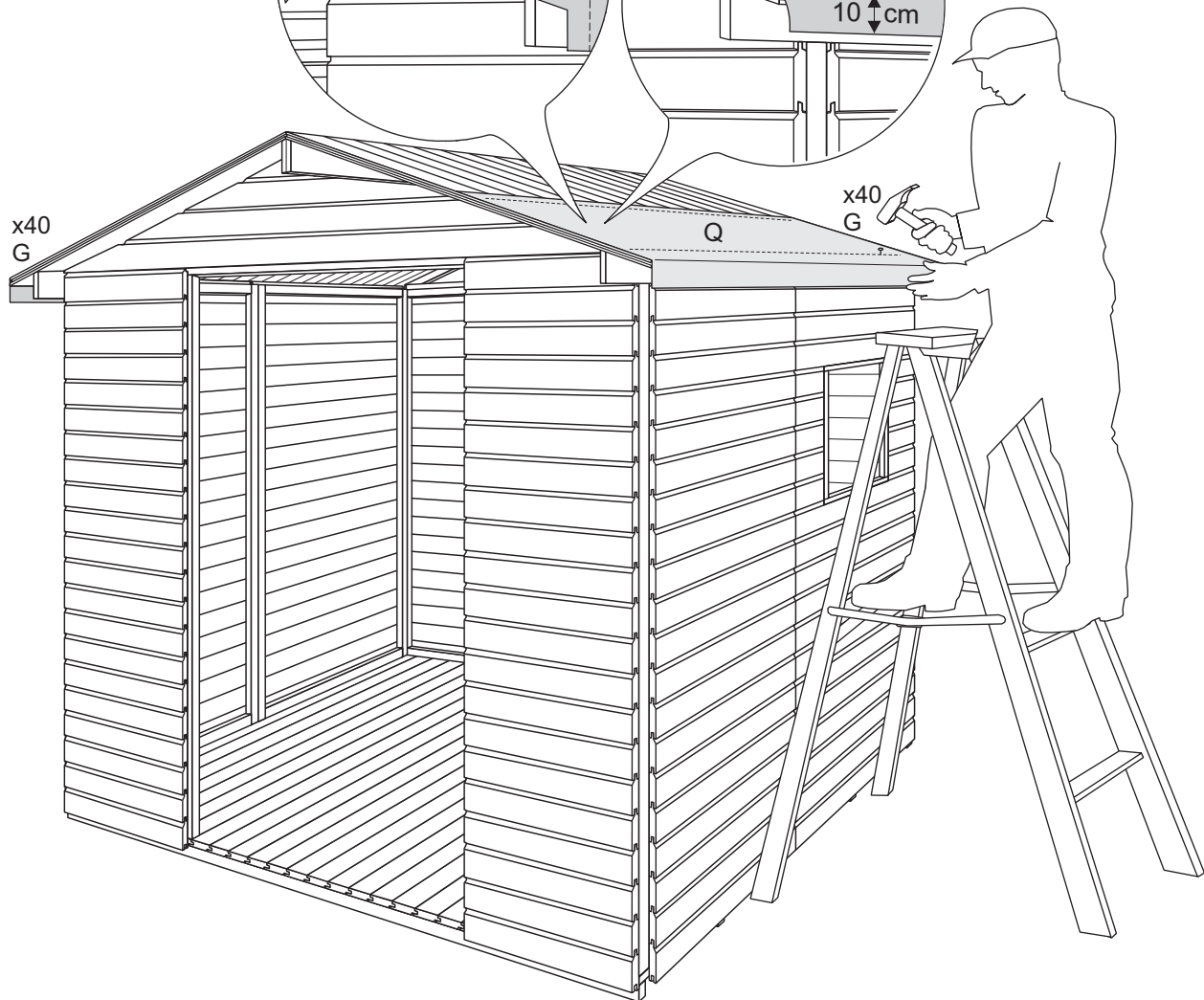
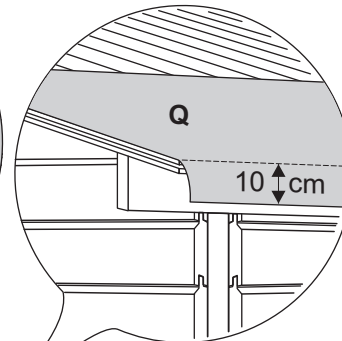
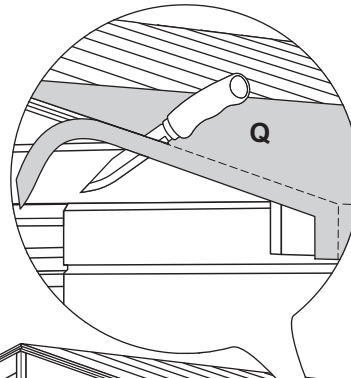
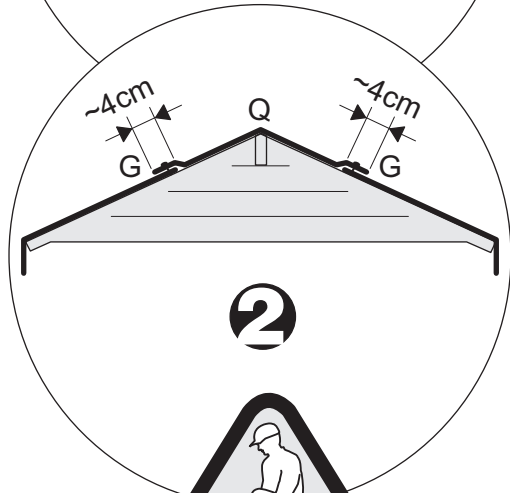
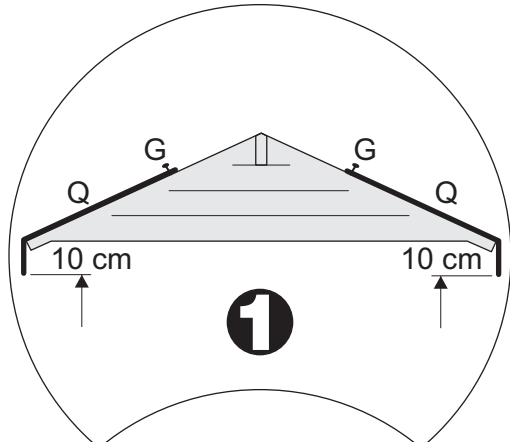
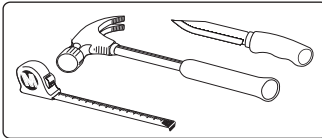
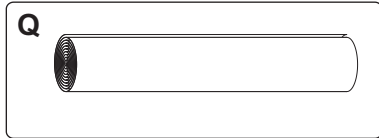
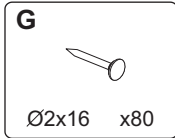

17. step: Roof battens • Dachleisten • Plinthes du toit • Listelli del tetto

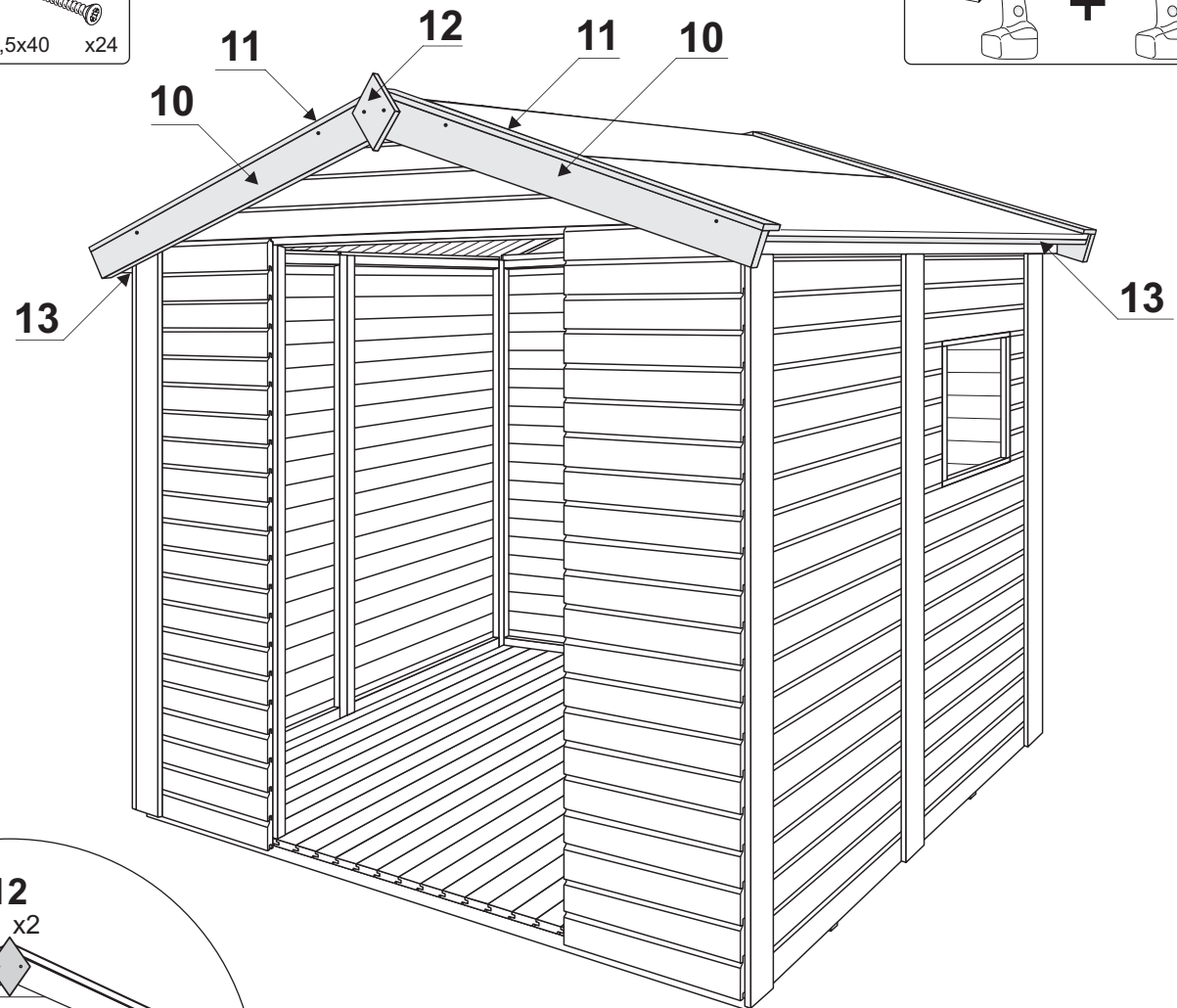
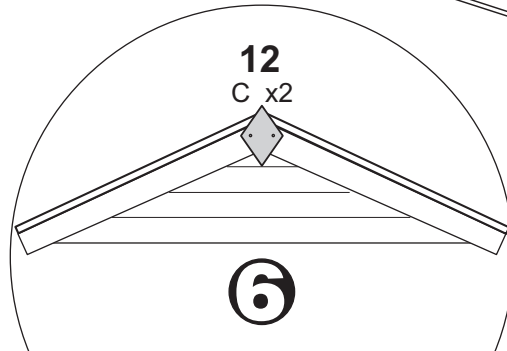
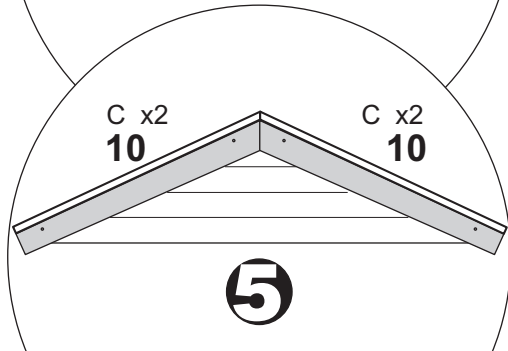
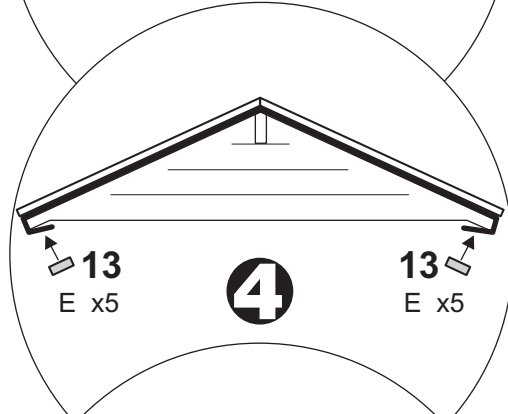
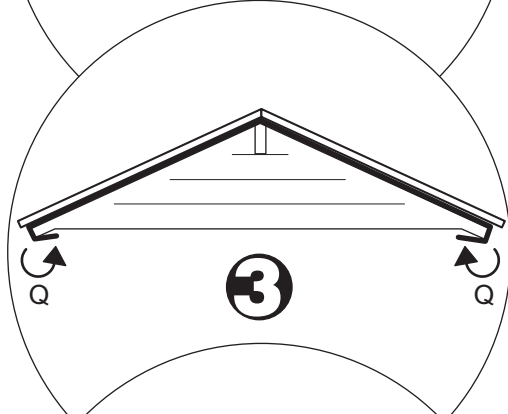
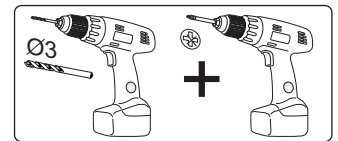
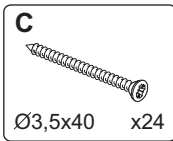
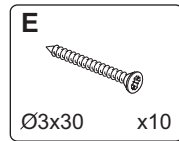
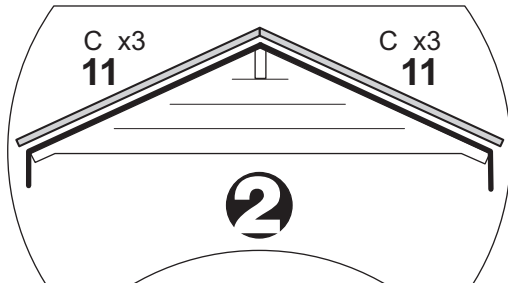

18. step: Wall battens • Wandleisten • Plinthes du mur • Listelli parete

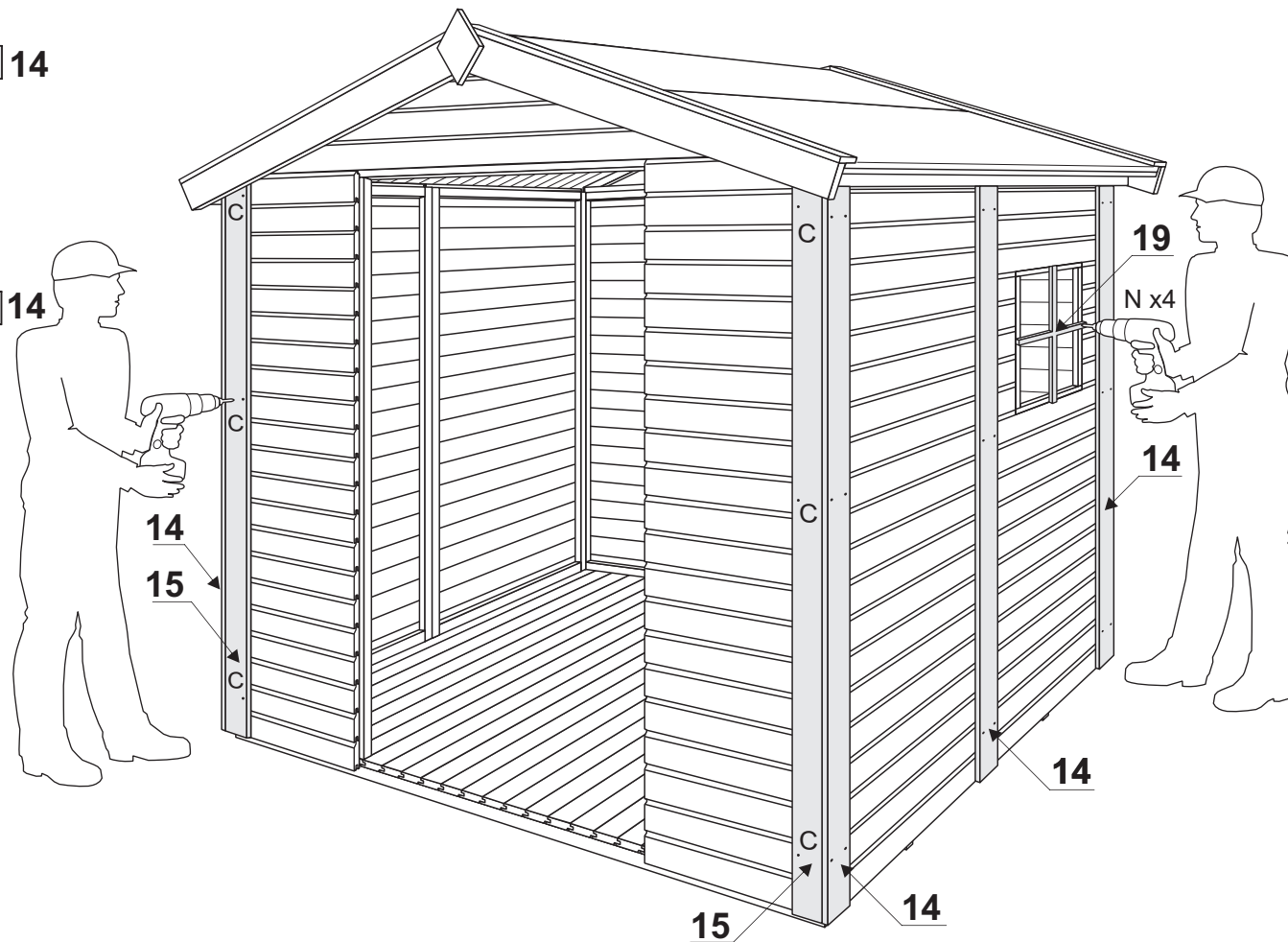
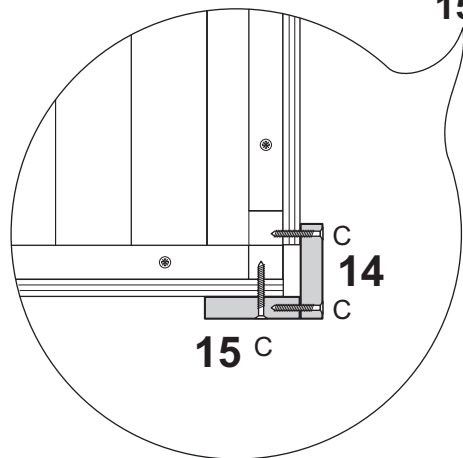
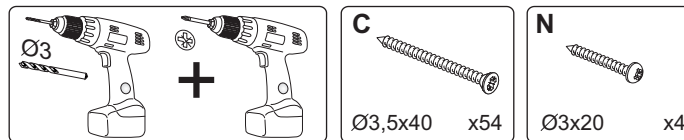
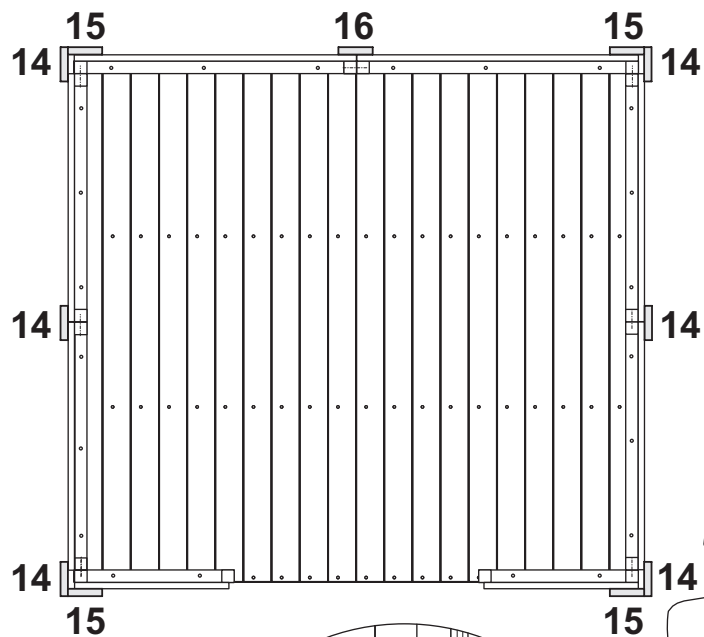

19. step: Door lock/Hinges • Türschloss/Türscharniere • Serrare/Gonds de la porte • Serratura/Cardini della porta

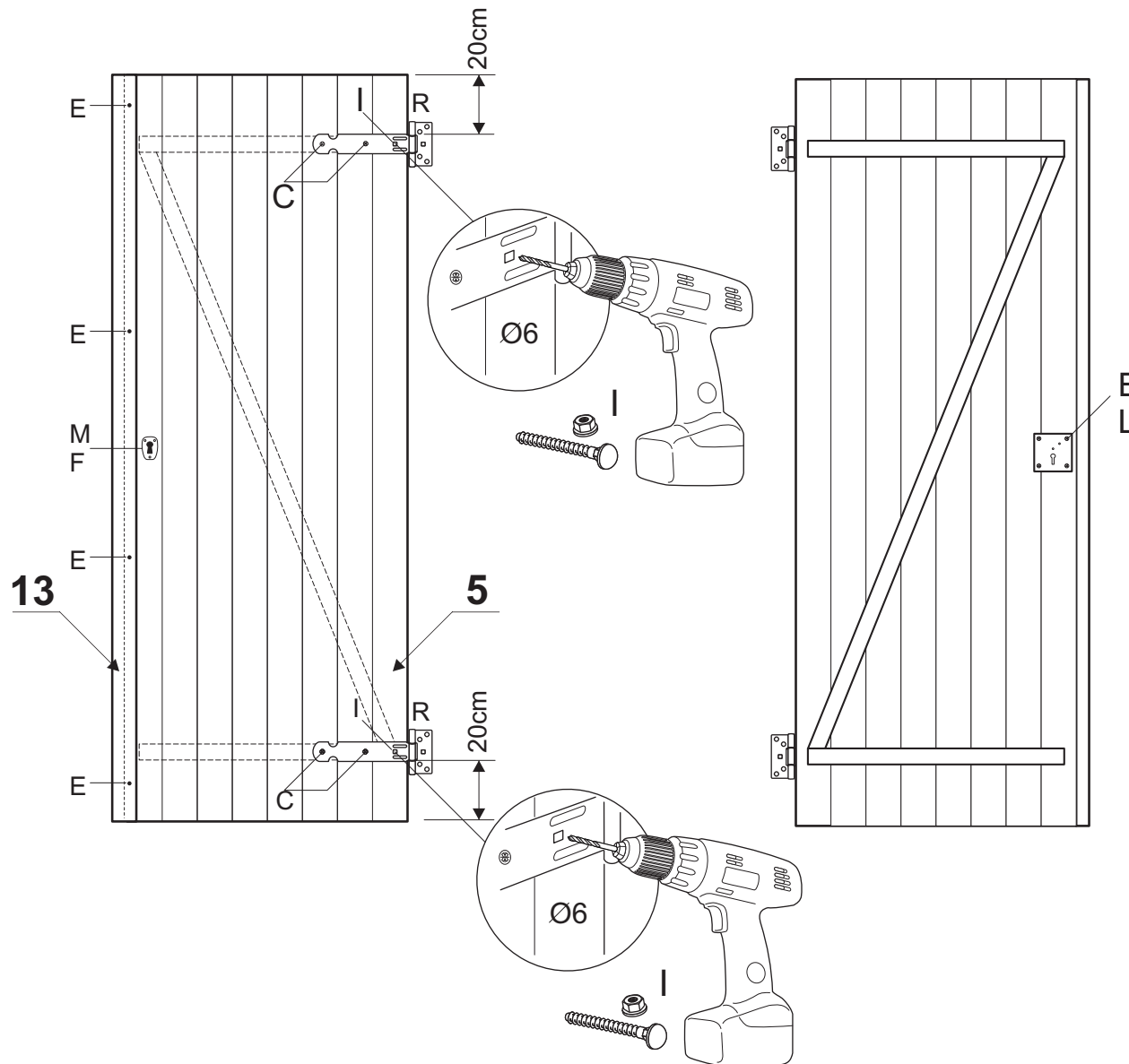
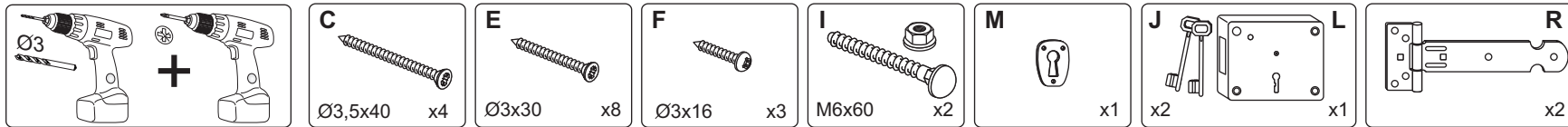

20. step: Door • Tür • Porte • Porta

