



All weather design | Conçu pour résister aux différentes conditions climatiques | Diseño apto para todo tipo de climas | Wetterfest | Ontworpen voor alle weersomstandigheden | Design per tutte le stagioni | Design para todos os climas



Lockable (lock not included) | Verroullbaar (verrou non inclus) | Abschließbar (Vorhängeschloß nicht im Lieferumfang) | Apto para candado (que no se incluye) | Afsluitbaar (slot niet inbegrepen) | Richiudibile (lucchetto non incluso) | Pode ser Trancado (fecho não incluído)











CAUTION | AVERTISSEMENT | WICHTIG | ADVERTENCIA WAARSCHUWING | ATTENZIONE | ATENÇÃO

- 1. Some parts have metal edges. Please be careful when handling components. Always wear work gloves
- 2. Certaines pièces ont des bords en métal. Soyez prudent en les manipulant. Portez toujours des gants de travail.
- 3. Manche Teile haben Stahlkanten, bitte seien Sie vorsichtig beim Umgang mit diesen. Tragen Sie bei der Montage des Gartenschuppens oder Wartungsarbeiten stets Arbeitshandschuhe.
- 4. Algunas partes incluyen bordes metálicos. Tenga cuidado al manejar estos componentes. Use siempre guantes de trabajo.
- 5. Sommige onderdelen hebben stalen randen. Wees voorzichtig met het omgaan met deze onderdelen. Draag altijd werkhandschoenen.
- 6. Alcune parti presentano bordi in acciaio. Fare attenzione nel maneggiare i componenti.
- 7. Indossare sempre guanti da lavoro.
- 8. Algumas peças têm extremidades de aço. Tenha cuidado ao manusear este componentes.



- 9. ASSEMBLY PARTS ● PIÈCES À ASSEMBLER ● MONTAGETEILE ● MONTAGESTUKKEN ● PIEZAS DE ENSAMBLE
- 10. PARTI DA MONTARE ● PEÇAS DE MONTAGE ● ΑΝΤΑΜΑΚΤΙΚΑ

Please check all parts and components to ensure that there are no damages or missing items BEFORE starting the construction of the product ● Assurez-vous que les parties et les éléments ne sont pas endommagés et qu'aucun ne manque AVANT de commencer le montage de ce produit ● Bitte überprüfen Sie alle Einzelteile und jegliches Zubehör, um sicherzugehen, dass keine Teile beschädigt sind oder fehlen, BEVOR Sie mit der Montage des Produkts beginnen ● Controleer alle onderdelen en componenten om te verzekeren dat er geen schade of ontbrekende items zijn VOOR dat u het product in elkaar begint te zetten ● ANTES de comenzar la construcción del producto, compruebe todas las partes y componentes para asegurarse de que no hay daños y de que no falta ningún elemento ● Si prega di controllare tutti i pezzi ed i componenti per accertarsi che non ci siano danni o elementi mancanti PRIMA di montare il prodotto ● Por favor, verifique todas as peças e componentes para garantir que não há danos ou itens incompletos ANTES de iniciar a construção do produto ● Ελέγξτε όλα τα μέρη και εξαρτήματα για να βεβαιωθείτε ότι δεν υπάρχουν φθορές ή λείποντα μέρη ΠΡΟΤΟΥ ξεκινήσετε την κατασκευή του προϊόντος.

| | | | |
|---|---|--|---|
|  SP2/CI2(x1) |  Stück = 20,- |  SP3/CI3(x1) |  Stück = 20,- |
|  M1(x1) |  Stück = 35,- |  SP1/CI1(x2) | Set = 25,- |
|  M6(x2) |  M2(x2) |  W(x2) | |

- 1.  M1(x1)  SP1/CI1(x2)

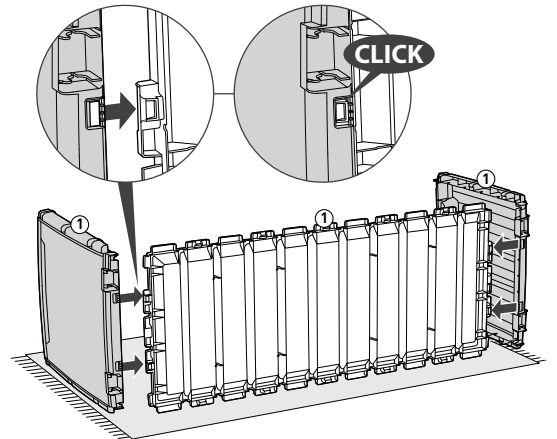

- 2.  SP2/CI2(x1)  SP3/CI3(x1)

