

50984

Schaumeffektdüsen
foam effect nozzles
buses à jet moussant
toberas con efectos de espuma

Schaumsprudler
35-10E

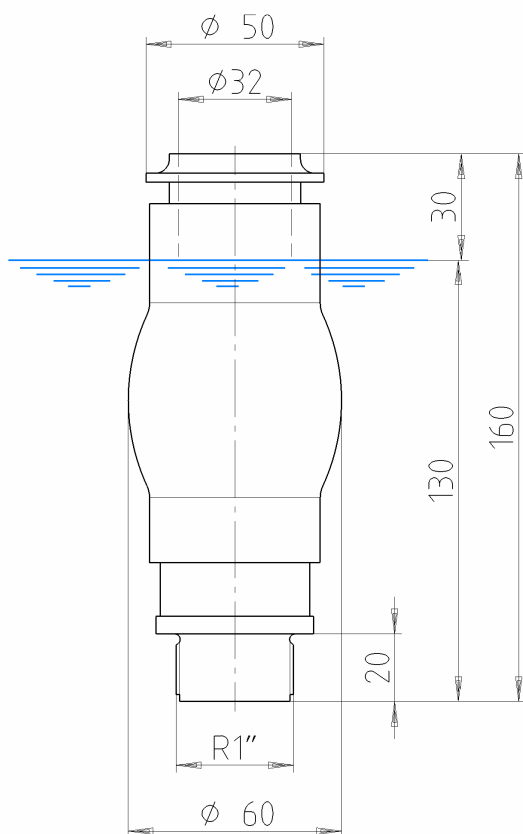

Hydr. Daten	Schaumsprudler 35-10 E		
Hydr. Data	DWB	DDB	DDB
FH	L/min	mWS	bar
0,25 m	47	1,0	0,1
0,50 m	55	1,3	0,1
0,75 m	71	2,1	0,2
1,00 m	80	2,7	0,2
1,25 m	89	3,3	0,3
1,50 m	97	3,9	0,4
1,75 m	104	4,6	0,4
2,00 m	111	5,2	0,5
2,50 m	123	6,4	0,6
3,00 m			

MA	Edelstahl/Kunststoff
GW	0,5 kg
Art.-Nr.	706-500
Id.-Nr.	50984

DDB = Düsen-Druckbedarf, Ma = Material, GW = Gewicht

FH = Fountain height, DWB = Nozzle Water demand,
DDB = Nozzle Pressure demand, MA = Material, GW = Weight

